



**HORNE DUAL CONTROL TSV1-3 THERMOSTATIC SHOWER PANEL
 WITH (ASSISTED SHOWERING) AUTOMATIC DIVERTER
 INSTALLATION, COMMISSIONING & MAINTENANCE INSTRUCTIONS**

These instructions (L-180) cover the HORNE range of pre-plumbed shower panels with DUAL OUTLETS and AUTOMATIC DIVERTER. There are separate instructions for panels with a single outlet (L-189); and others for showers with push-button flow control (L-84, L-178).

0.1 Approvals

The TSV1-3 valve is independently tested & approved by an ISO17025 Accredited Test House to all the requirements of Department of Health - HTM 04-01: Supplement *Performance Specification D 08: Thermostatic Mixing Valves (Healthcare Premises)*, to the following designations and for the following applications:

HP-S	Shower with supply pressures of 1 – 5Bar and unrestricted flow rate
LP-SE	Shower with supply pressures of 0.2 – 1Bar and unrestricted flow rate

It also complies with Regulation 4 of the Water Supply (Water Fittings) Regulations 1999.

0.2 Backflow Prevention

The hot and cold inlets to the TSV1-3 valve are fitted with single in-line Reg 4 approved DN15 Check Valves.

0.3 Supply Water Pressure Requirements

The minimum water pressure required to achieve a spray at the spray head is a dynamic head of 20m (30 psi, 2 bar) at the spray head.

Note that dynamic head is measured with the water running.

Where the TSV1-3 panel is fed by supplies with differing pressures, a pressure-reducing valve (PRV) may be required on the inlet with the higher pressure. If the lower inlet pressure is low enough (typically lower than 1Bar dynamic) that the flow-regulator in the fixed head outlet fitting (see page 11) can be removed, then a PRV should not be required. If the lower of the 2 supply pressures is higher than around 1Bar, then a flow-regulator will likely be required to control flow. If the flow-regulator is installed, and the supply pressures are substantially unbalanced, then a PRV could also be needed to prevent pulsing of the flow. Although this has minimal effect on thermostatic control, the flow pulsing is often considered undesirable.

Note that output flowrate is always determined by the lower of the two inlet pressures.

0.4 Operating Conditions Required for TMV Type 3 Compliant Installations

	High Pressure
Maximum Static Pressure	10Bar
Flow Pressure, Hot & Cold	2 to 5Bar
Hot Water Supply Temperature	55 – 65°C
Cold Water Supply Temperature	5 – 20°C
Minimum Temperature Differential (Hot/Mixed, Mixed/Cold)	5K (=5°C)

OUTSIDE THESE CONDITIONS OF USE VALVES CANNOT BE EXPECTED TO OPERATE AS TYPE 3 VALVES.

0.5 Temperature Adjustment Range

The mixed water temperature can be adjusted from cool through to a top limit (which can be preset during installation – factory set to approx. 41°C - with full anti-scald protection throughout the range).

0.6 Water and Energy Conservation

The fixed shower-head of the T605 panel is fitted with a brown flow regulator to reduce the flow rate, and conserve water and energy. The drawings at the end of this document provide information for accessing the flow restrictors/regulators for removal or replacement.

0.7 Alternative Water Entry

Note that panels with rear water-entry, with flexible soft-PEX hoses are also available. More specific instructions for installation of these panels is given at the end of the installation section.

SECTION 1: INSTALLATION

The surface mounting enclosure is supplied with fixings to attach it to a wall. However, consideration should be given to the type of wall fittings required, as different substrates will require different fittings. It is the responsibility of the installer to ensure that the fixings used are appropriate for the wall substrate.

The hot pipe is on the left, and cold on the right, when viewed from the user's perspective.

1.1 Recommended Mounting Heights – Guidance Only

When considering what height to mount the TSV1 shower panel, local needs should be accounted for (e.g., height of users, wheelchair or ambulatory users*, size of shower enclosure, etc). As a general guide, identify a suitable position for the pre-plumbed enclosure, and mark a spot for the support screw on the wall 2.0 metres above the finished floor level and on the centreline of where the panel is to go.

* For accessible and Changing Places installations, please refer to Building Regulations Doc M and BS8300 for appropriate guidance.

1.2 Mark the position for the panel

Identify a suitable position for the pre-plumbed enclosure and mark a spot for the support screw on the wall on the centreline of where the panel is to go, at the height indicated in the table above.

1.3 Install the Support Screw

Drill a hole in the wall and insert a wall plug and screw (7mm hole if using the supplied plug), leaving the head of the screw protruding approximately 12mm from the wall. Note that a corrosion resistant stainless-steel screw is supplied for this purpose.

REMOVE COVER SCREWS
AND TOP COVER

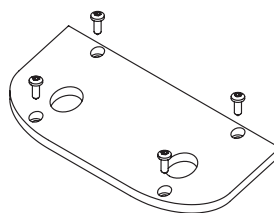

HANG ENCLOSURE
ON SUPPORT SCREW

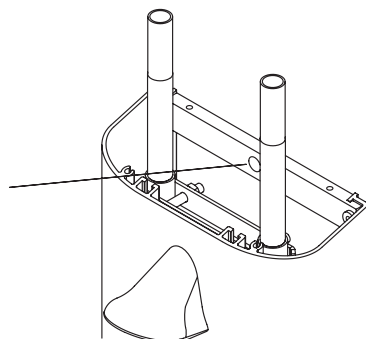

Fig.1

1.4 Hang the Enclosure on the Support Screw

Except where the panel includes an integral ILTDU, release the top cover of the pre-plumbed enclosure by removing the four screws. Hang the pre-plumbed enclosure on the support screw by the larger hole in the middle of the back strap and let this take the weight of the enclosure.

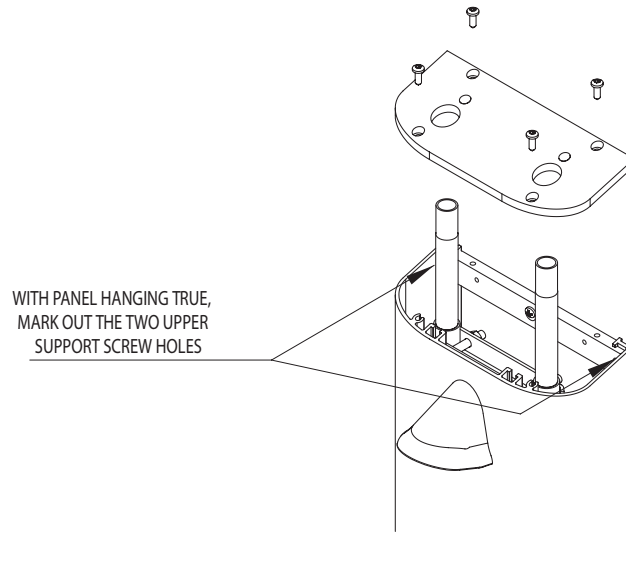

Fig.2

1.5 Mark out the Four Support Holes

Ensure that the enclosure is hanging true and then mark out the holes for the 2 upper support screws. Remove the bottom cover of the pre-plumbed enclosure and mark out the 2 lower support screws (See Fig. 2).

1.6 Drill Support Holes

Carefully remove the pre-plumbed enclosure from the temporary support screw and, being careful not to scratch the enclosure or its covers, lay it down where it will not be damaged. Drill 4 x support holes (7mm for the supplied plugs) to mount the panel.

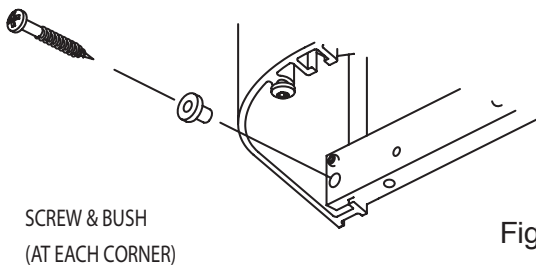
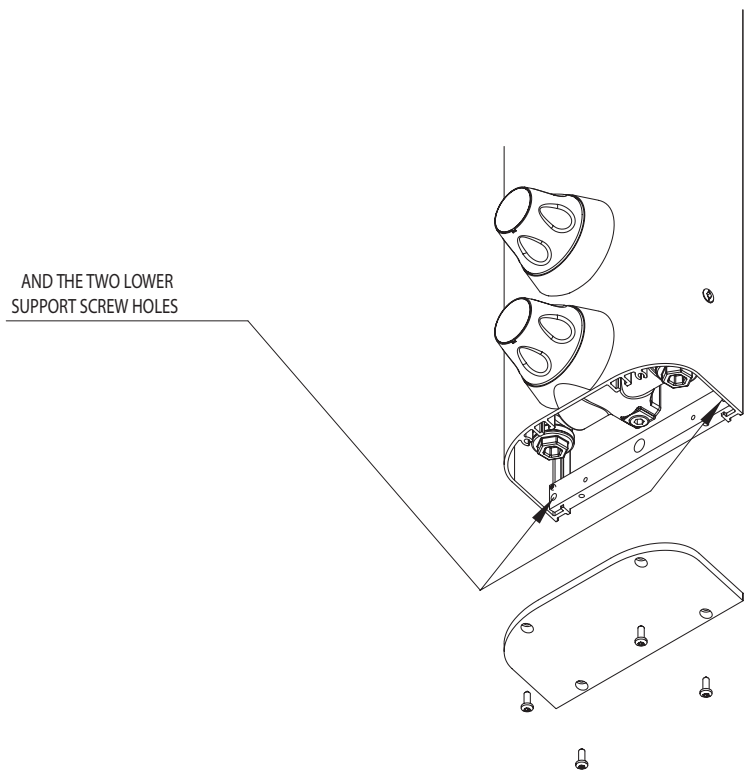

Fig.3

1.7 Attach the Unit to the Wall

Carefully re-hang the pre-plumbed enclosure on the temporary screw. Put the 4 supplied screw bushes in the mounting holes in the panel and then attach the panel firmly to the wall using 4 stainless-steel screws. A bead of silicon mastic can be used, if required, to cover any gaps behind the panel on uneven walls. Do not mastic the lower End Cap to the wall.

N.B. It is important to use the supplied screw bushes.

1.8 Connect the Supply Pipes

N.B. Except where the panel includes an integral ILTDU, ensure that the top cover of the pre-plumbed enclosure is replaced prior to connecting up the supply pipes. The fitting of isolation valves is required as close as practicable to the water supplies inlets of the shower panel.

Connect the hot water supply to the left-side inlet, and cold water to the right-side inlet (See Fig. 4).

DO NOT OPEN THE WATER SUPPLIES AT THIS STAGE AS THEY HAVE NOT BEEN FLUSHED OUT TO REMOVE THE DEBRIS IN THE PIPEWORK. SUCH DEBRIS CAN DAMAGE THE THERMOSTATIC VALVE

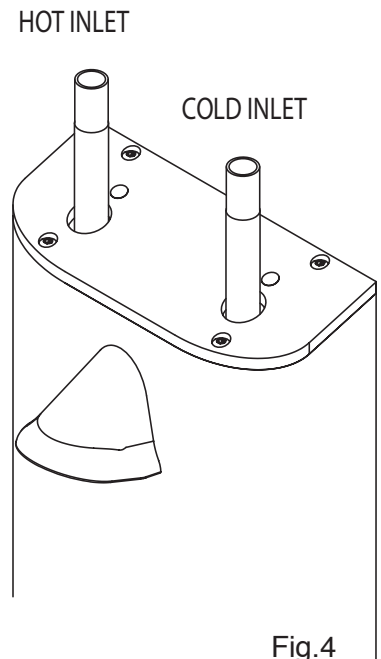

Fig.4

1.9 Flush the Pipework

Flush out the pipework in accordance with Water Bylaws 2014 (Scotland) and BS EN 806. The use of a Horne flushing kit is strongly recommended, because this connects directly to the water inlets to the mixing valve. See Figs. 5 and 6.

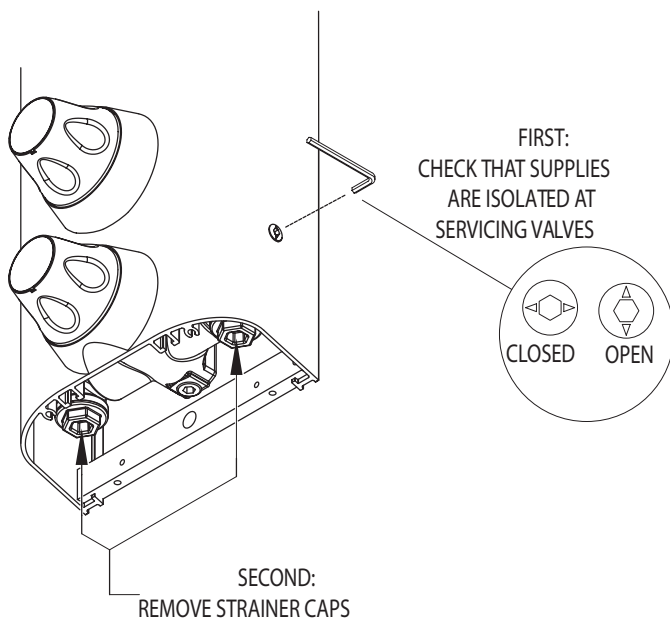

Fig.5

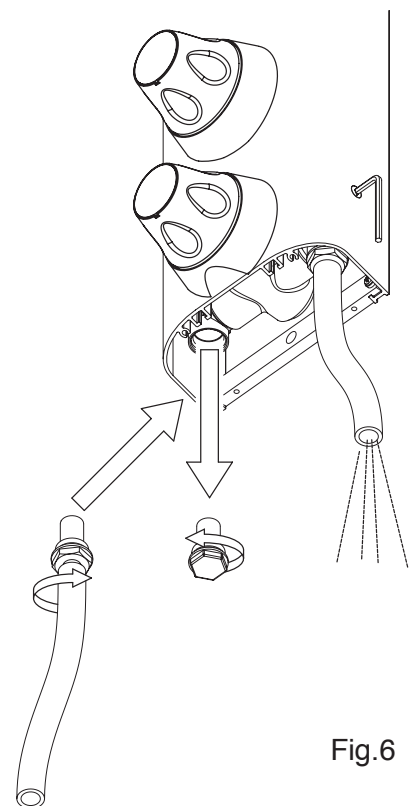

Fig.6

Access to the flushing points is gained from underneath the casing through the lower end cap. Isolate the water using the low-level servicing valves located on the side of the panel (Fig. 5) using a 4mm hex key. Remove the strainer cap with the strainer basket and screw in the flushing adapter. Place the end of the flushing hose in a drain or container and turn on the supply to flush **AT FULL BORE** until any pipework which has been worked on is cleared. After flushing, remove the flushing adapter and replace the strainer cap. Repeat for both hot and cold supplies. See Fig. 5 and 6.

NOTE THAT IF THE SYSTEM IS NOT TO BE COMMISSIONED IMMEDIATELY AND/OR THERE IS ANY DANGER OF FREEZING THEN THE PIPES AND VALVE MUST BE DRAINED TO AVOID DAMAGE.

OPEN THE STRAINER CAPS FOR THIS PURPOSE.

1.10 Test for Leaks in Pipework

Ensure that the TSV1-3 on/off control is closed (turned fully clockwise) and open the supplies. Open the servicing valves on the TSV1 casing (See Fig. 5). Open the supplies to the panel, adjust the temperature control and check for any water leaks upstream of the thermostatic valve. Make good any leaks found. The valve is now ready for commissioning.

Note that if the controls, enclosure and shower accessories require cleaning then care must be taken not to scratch them in the process. Wash off any surface dust with the shower spray before cleaning with soapy water.

DO NOT USE ANY ABRASIVE CLEANERS OR SOLVENTS OR THE SURFACES MAY BE DAMAGED.

1.11 Supplementary Installation Instructions for ...B Variants [Hose Inlets from Rear].

TSV1 shower panels are available in versions with flexible braided stainless steel inlet hoses rather than top entry copper pipework. The hoses used are UK Water Reg 4 Approved SOFT-PEX (cross-linked polyethylene). They are not EPDM lined. These shower versions have Product Reference codes with the suffix B, e.g. T605B.

The main difference, from an installation point of view, is that the water supplies may have to be connected before the pre-plumbed enclosure is attached to the wall. Accordingly, point 7 on the attached installation instructions (Connect the Supply Pipes) should be performed before point 6 (Attach the Pre-Plumbed panel to the Wall) unless alternative access is available to the connections, e.g. via an access panel.

Note that the braided hose inlets are colour coded with BLUE for the Cold Water Supply and RED for the Hot Water Supply.

Care should be taken to ensure that the weight of the pre-plumbed enclosure is taken by the mounting screws and NOT by the hoses.

SECTION 2: COMMISSIONING

Commissioning the unit involves flushing the water supply; setting the temperature; and finally performing a cold-water isolation test to confirm the safe operation of the thermostatic valve as fitted. Flushing is included in the Installation section to ensure it is done as soon as possible after installation but should be considered vital to the commissioning process. Commissioning is essential to establish a reference point for future in-service tests, and to ensure the thermostatic valve works correctly under site conditions.

2.1 Flushing

Unless you are absolutely certain that this has been done, flush the pipework: see section 1.9 above.

2.2 Pre-Checks

Ensure that the NHS designation of the valve matches the intended application, that both hot and cold-water supplies are open and at, or near, their design temperatures and pressures, that they are within the requirements of the valve as outlined in section 0.4. Also ensure that the servicing valves are open.

2.3 Temperature Setting

The TSV1-3 is set in the factory to verify correct good thermostatic performance, but this must be checked on site during commissioning to ensure that the site conditions do not impair the operation of the valve. If necessary, reset the maximum outlet temperature to 41°C.

- 2.3.1 Set the temperature control to the maximum temperature setting (rotate the control anticlockwise until it stops).
- 2.3.2 Fully open the on/off control by turning it anticlockwise. Putting a burst polythene bag over the fixed shower head will help to catch and deflect the spray during commissioning.

- 2.3.3 Allow the shower to run at maximum temperature setting until the water temperature has stabilised. Should the temperature rise, or drop, in an uncontrolled fashion, then the hot and cold supplies are probably reversed. Correct this before proceeding.
- 2.3.4 During commissioning, the valve MUST be adjusted DOWN to temperature. This is to ensure that the hot water system is capable of supplying water, at the working flowrate, in excess of the required outlet temperature by a margin of at least 5°C. Note that this is not always the case with instantaneous water-heaters. To do this, set the valve to 5°C higher than required; measure and confirm the elevated temperature, and then reduce the temperature to the required level. If the valve cannot be set to 5°C higher than required, then the outlet temperature is being controlled by the inlet conditions and not safely by the valve, therefore the commissioning is not complete, and **VULNERABLE USERS SHOULD NOT BE ALLOWED TO OPERATE THE SHOWER.**
- 2.3.5 To adjust the set maximum temperature, remove the temperature control cap (prize plastic ones off using a small screwdriver; or unscrew the metal ones - Horne tool 23-5459 or nitrile gloves are helpful for grip) and adjust the small, slotted screw in the centre of the spindle. Adjust the screw anticlockwise to increase the temperature, clockwise to decrease the temperature. See Fig. 7.
- 2.3.6 After setting the maximum temperature on the knob, turn the shower on and off a few times and check that the maximum setting is correct.

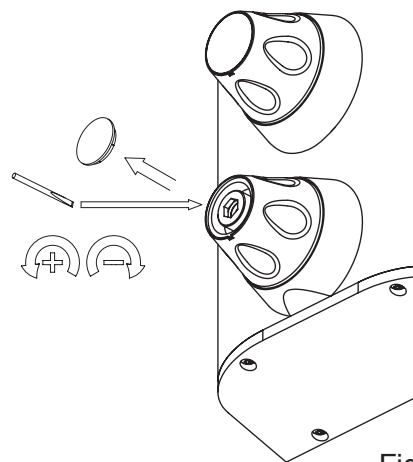

Fig.7

2.4 D08 Compliance

Note that, to comply with D08, the final stabilised Mixed Water Temperature should not exceed 43°C. Record the commissioning information, including equipment used, on the attached commissioning sheet to permit the in-service performance of the valve to be assessed in the future.

2.5 Cold Isolation Test

- 2.5.1 Finally, check the thermal shut-off facility of the TSV1-3 by performing a Cold Isolation Test (sometimes colloquially called a “fail-safe” test) as follows. With the shower running full, close the cold (i.e. right side) servicing valve. [The Servicing Valve is closed when the arrows are in the horizontal position, and open when they are in the vertical position: see Fig. 5]. If there is any flow after 5 seconds, this must amount to no more than 120ml in 60 seconds of collecting. If there is more than this amount, find possible corrective actions in the “Maintenance” section below. If the Cold Isolation Test is satisfactory, restore the supply and note the final stabilised temperature in the commissioning log. This should be within 2°C of the original temperature, and must not exceed 43°C. Generally, the mixed water temperature should not rise by more than 2.9°C during this cold-water isolation test. Record the result of this on the attached commissioning sheet.

Note that the incoming hot-water temperature must be maintained in the range described in the table at the bottom of page 1 for this test to be valid. Refer to the maintenance section of this booklet or phone the factory for advice, if necessary.

Putting a burst polythene bag over the fixed shower head will help to catch and deflect the spray and avoid getting wet.

2.6 Test the Check-Valves

Although check-valve failures are rare, verifying their operation at commissioning time in a large installation can give peace of mind later. Refer to section 3.8 .

SECTION 3: MAINTENANCE

Maintenance of all Thermostatic Mixing Valves is essential to ensure the product continues to perform to specification after installation and continues to afford scald protection. Record all maintenance carried out on the attached commissioning and maintenance record.

3.1 In-Service Testing

Periodic testing should be carried out to check whether any deterioration has occurred in the performance of the shower valve. The results of these tests, and the equipment used, should be recorded on the Commissioning, Maintenance and In-Service Testing Sheet at the back of these instructions. Fill in all the parameters requested on the sheet.

Note that instrumentation to the same specification should be used each time when measurements are taken to ensure consistency of results. Record all the information on the In-Service Testing sheet at the back of these instructions.

Also record any requirement to adjust the Mixed Water Temperature on the in-service testing record.

NOTE: A THERMOSTATIC MIXING VALVE IN NEED OF MAINTENANCE CAN BE UNDETECTABLE IN NORMAL USE AND ONLY BECOME APPARENT WHEN DISRUPTION OCCURS IN THE HOT OR COLD-WATER SUPPLY TEMPERATURES OR PRESSURES. IN SERVICE TESTING SHOULD BE CARRIED OUT AT A FREQUENCY DETERMINED BY LOCAL RISK ASSESSMENT TO DETECT ANY SUCH DETERIORATION.

3.2 Routine Servicing

- 3.2.1 Replace the “O” rings every three years (Maintenance kit with spare “O” rings available). It is especially important to replace the slide-valve seal, located in a groove in the valve body. Horne tool 4411 is helpful for this job. See the Horne website “maintenance” section for further instruction and videos.
- 3.2.2 Replace the Thermostat Element every 6 years, or more often if problems are experienced or in installations where the water is aggressive.
- 3.2.3 Replace the slide-valve assembly if it becomes damaged. This may happen due to scale or grit in the water.
- 3.2.4 The multi-turn On/Off mechanism should be replaced if it leaks. Ensure the on/off assembly is torqued down to 25 Nm (18Lbf.ft) on re-fitting to prevent the user from inadvertently unscrewing the assembly during flow control. Do not over tighten the assembly.

3.3 Strainer Baskets

Initially check the strainer baskets for debris every three months and clean if required. This period can perhaps be increased later if it is established that the water is generally clean and free of debris.

3.4 Cold Isolation Test - Corrective Actions for Failure

- 3.4.1 Regularly perform a Cold Isolation Test and check the maximum temperature setting as described in the “Commissioning” section above. If the valve fails this test then consider the following:
- 3.4.2 Perform an Isolation Test, but shut the hot instead of the cold. If this results in a similar rate of flow as when shutting the cold then consider that there may be a problem with the slide-valve seal. Follow the routine servicing instructions below.
- 3.4.3 Opening and cleaning the valve can cure problems caused by dirt in the pipework which has migrated into the valve, but note that if water cleanliness is poor, or flushing is not carried out, then dirt can damage the slide-valve knife-edge faces. This will necessitate replacement of the slide-valve.
- 3.4.4 Cleaning/dressing of the hot valve seat may be necessary if the valve is old and/or scaled. This can be done with Horne tool 5395, and some toothpaste or fine grinding paste.
- 3.4.5 Failure of the Cold Isolation Test can be caused by hot water in the cold supply: test the check-valves.
- 3.4.6 In the water supply is ‘hard’, then de-scaling of the valve may be necessary. All rubber parts must be removed prior to de-scaling. Do not forget the Slide-Valve Seal located inside the TSV1-3 body, which should always be replaced with a new seal after removal. Maintenance kits are available which contain “O” rings and/or the Thermostatic Element. Smear all “O” rings with silicon oil prior to installing them.

3.5 Notes on Dismantling

- 3.5.1 All internal components of the thermostatic valve can be removed from the front of the panel by removing the components shown in drawing 8341 below. There is no need to remove the panel from the wall unless you wish to remove the valve from the panel, to de-scale it for example.
- 3.5.2 Treat all parts with care when removing them from the valve body. Note especially that the slidevalve is a precision component and can easily be damaged.
- 3.5.3 Do not forget the slide-valve seal, partially hidden in a groove in the valve-body. Horne tool 4411 can be used to remove it. Be careful not to scratch the groove sides whilst removing the seal. This and all other plastic/rubber parts must be removed before de-scaling.

3.6 Notes on Descaling (see drawing 8341 below)

- 3.6.1 If the valve body requires de-scaling, first remove the valve from the panel (see section 3.9). Remove all o-ring seals and internal parts, then use a proprietary de-scaling fluid. Do not put the thermostat element or any plastic/rubber parts in de-scaling fluid.
- 3.6.2 Inspect the condition of the "Hot Valve Face", with which the knife-edge of the slide-valve mates, and the "Cold Valve Face". If the valve faces show signs of deterioration, they can be resurfaced as follows.
 - ◇ Re-surface the Hot Valve Face using a mandrel (Horne part no. 5395) and a water-soluble scouring paste (toothpaste works quite well).
 - ◇ Use P800 Grade wet abrasive paper on a flat surface to smooth the "Cold Valve Face" (ie, the end of the cover on which the slide-valve mates).
- 3.6.3 Prior to re-assembly of the valve, ensure it is clean and all debris is removed.

3.7 Notes on Re-assembly

- 3.7.1 Make sure all components are clean before re-assembly. It is recommended to fit new o-rings.
- 3.7.2 Ensure the slide-valve seal is fitted in the body and is in good condition.
- 3.7.3 Smear silicon oil (not grease) on all "O" rings prior to installation. Also lightly smear the outside diameter of the slide-valve with silicon oil before fitting.
- 3.7.4 Fit the components into the valve body using drawing 8341 (below) as a guide.
- 3.7.5 For optimal thermostatic performance, orient the visible tail end of the return spring towards the left side (hot inlet side) before inserting the slide-valve. Then turn the thermostatic adjustment to the full cold position *before* screwing on the cover.
- 3.7.6 Torque the TSV1-3 cover to 40 Nm (29Lbf.ft). This is to prevent the user from inadvertently unscrewing the cover during temperature adjustment. Do not over tighten the cover.
- 3.7.7 After any dismantling of the valve, perform a Cold Isolation Test per section 2.4 to verify correct re-assembly.

3.8 Testing of Check-Valves

The Check Valves prevent crossflow between hot and cold-water supplies under unequal pressure conditions and are designed for long life with no maintenance. Their function can be tested as follows:

- 3.8.1 To test the Check Valve on the hot side, shut off the hot supply and ensure the cold supply is open. Be prepared for leakage of trapped water from the pipe and remove the strainer basket on the hot side. Any continuing leakage evident from the strainer body is likely to be coming through the hot supply Check Valve (N.B. Ensure the hot isolating valve shuts off tightly, or it may cause leakage here). Testing of the cold-side check valve is a mirror of this process.
- 3.8.2 If either Check Valve is passing, then the inlet elbow (complete with Check Valve and strainer basket) should be replaced. It is not possible to satisfactorily remove the Check Valve itself from the inlet elbow and this should not be attempted. The shower valve body must be removed from the pre-plumbed enclosure to remove the inlet elbows. Pay attention to the section below on "removal of valve from panel", and fig.9.

3.9 Removal of Valve from Panel

If removing the valve from the panel, for example for descaling, then care should be taken over the low-level isolation actuators, which are connected to the valve via spring-loaded Oldham couplings. The 2 parts of the coupling can be held together by M2 screws (part no 41-5667, inserted down the 4mm hex hole), which prevent loss of the very small springs during assembly & disassembly. The complete coupling is part no. 43-5663.

3.10 External Cleaning

When cleaning the external levers or control knobs, use only a soft cloth and soap. Never use cleaners containing abrasives or solvents as they may damage the chrome plating.

3.11 Frequency Of Testing

The frequency of in-service testing depends upon the condition of the water passing through the TSV1-3. In-service testing must be carried out more frequently in hard water areas than in soft water areas. As a general guide, in-service testing should be carried out at intervals somewhere between 6 and 12 months. In-service testing should be carried out at least every 12 months and, where the water is hard, the interval may be less than 6 months. Experience of local conditions and the in-service testing record will dictate the required frequency of in-service testing. In the absence of practical experience of this, a first check 6 – 8 weeks after commissioning should be performed. If no problems are detected (and mixed water temp is within 1°C of the commissioning temp) then checking again 12 – 15 weeks after commissioning to help build up a history. The results should be recorded on the attached sheet. Any requirement to reset the mixed water temperature should be noted. If no such adjustments are required, then the next in-service tests can be scheduled for 24 – 28 weeks after commissioning. If small adjustments (1 to 2 K) are required then check the strainers for cleanliness, make sure the isolating valves are fully open and verify the check valves are operating correctly (see Maintenance Section). The next in-service test should be conducted 18 - 21 weeks after commissioning. If larger adjustments are required (>2K), then service work is required, and the in-service tests should be repeated 18 – 21 weeks after commissioning. Note that the pressure and temperatures of the supplies must be identical to those during commissioning for the in-service tests to be meaningful.

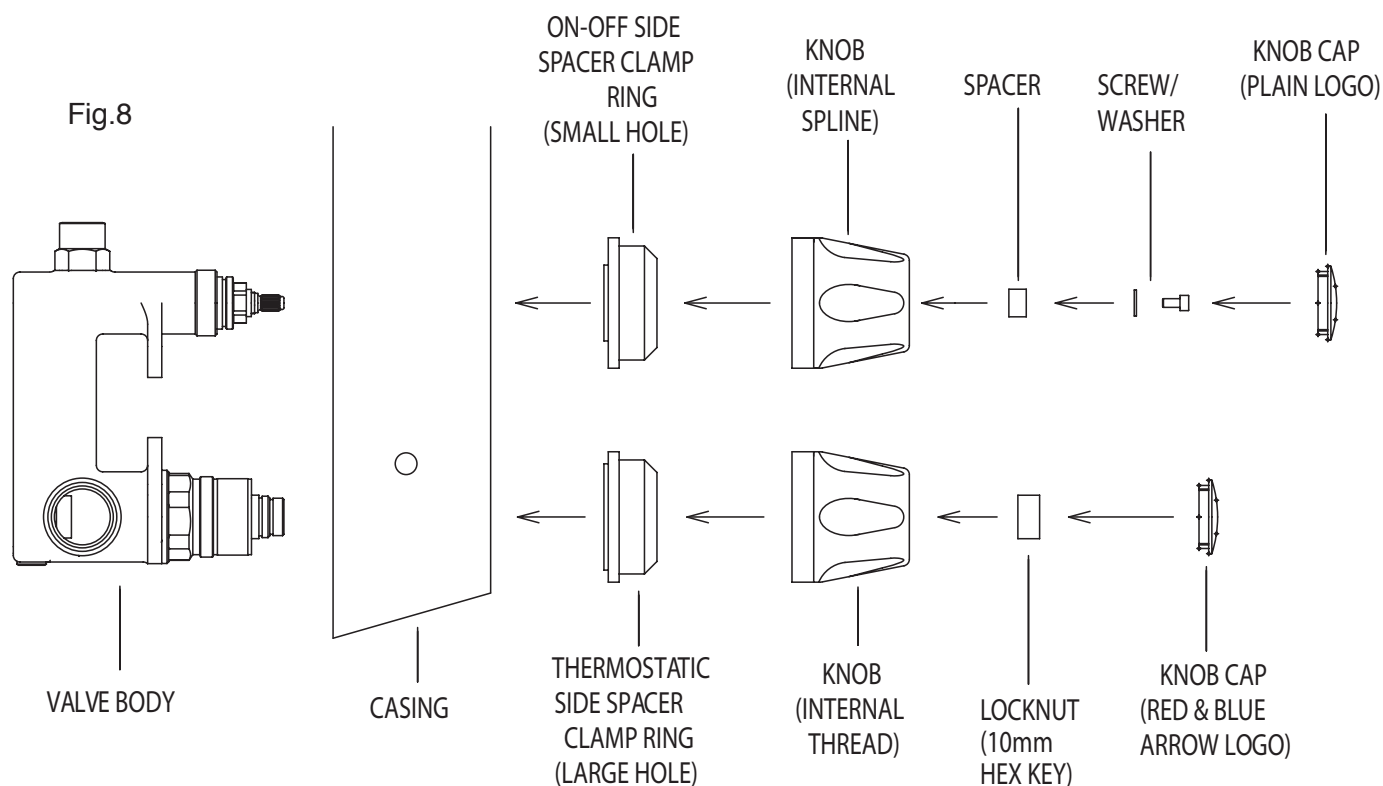

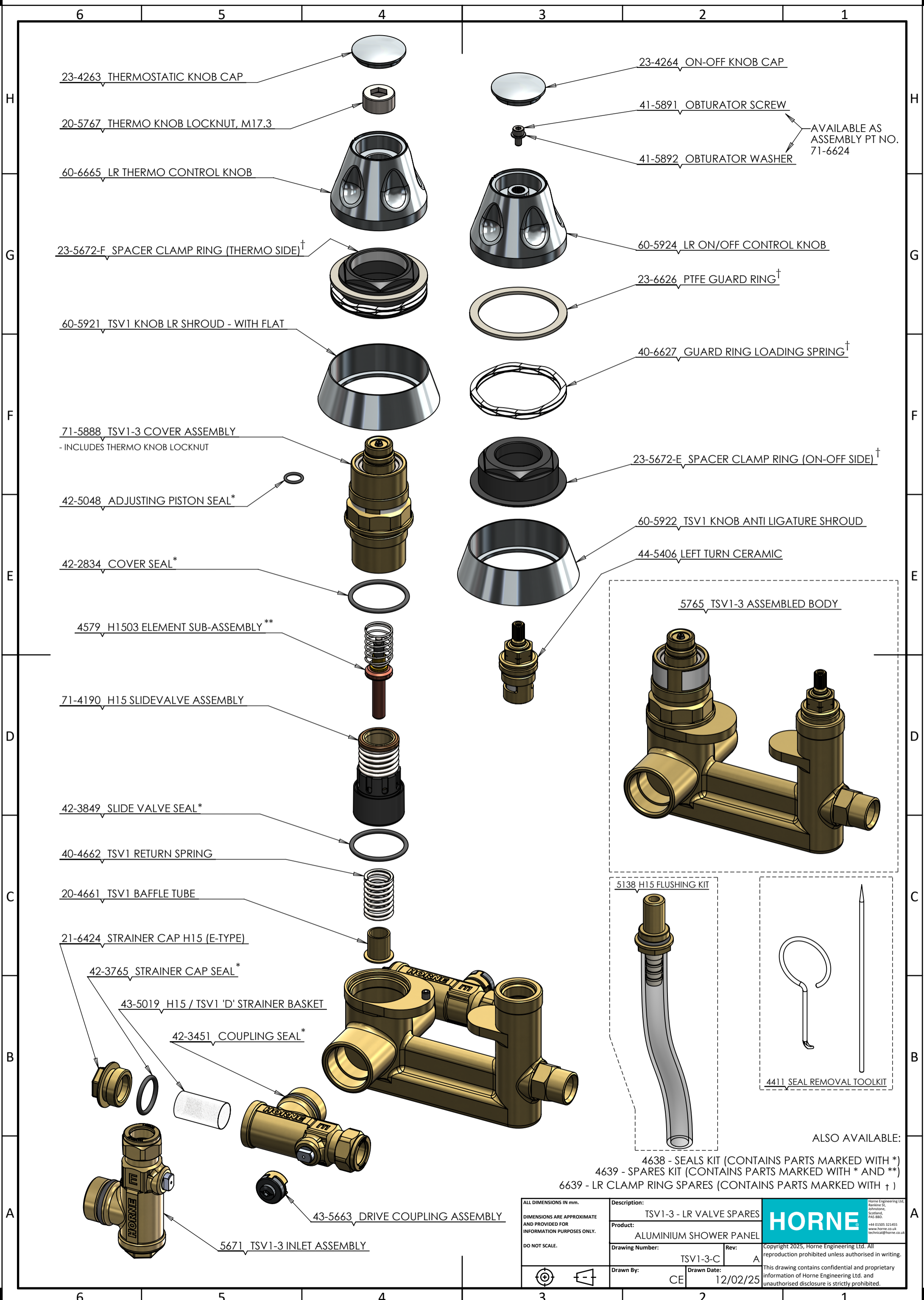

23-4263 THERMOSTATIC KNOB CAP

20-5767 THERMO KNOB LOCKNUT, M17.3

60-6665 LR THERMO CONTROL KNOB

23-5672-F SPACER CLAMP RING (THERMO SIDE)[†]

60-5921 TSV1 KNOB LR SHROUD - WITH FLAT

71-5888 TSV1-3 COVER ASSEMBLY
- INCLUDES THERMO KNOB LOCKNUT

42-5048 ADJUSTING PISTON SEAL*

42-2834 COVER SEAL*

4579 H1503 ELEMENT SUB-ASSEMBLY**

71-4190 H15 SLIDEVALVE ASSEMBLY

42-3849 SLIDE VALVE SEAL*

40-4662 TSV1 RETURN SPRING

20-4661 TSV1 BAFFLE TUBE

21-6424 STRAINER CAP H15 (E-TYPE)

42-3765 STRAINER CAP SEAL*

43-5019 H15 / TSV1 'D' STRAINER BASKET

42-3451 COUPLING SEAL*

43-5663 DRIVE COUPLING ASSEMBLY

5671 TSV1-3 INLET ASSEMBLY

23-4264 ON-OFF KNOB CAP

41-5891 OBTURATOR SCREW

41-5892 OBTURATOR WASHER

AVAILABLE AS
ASSEMBLY PT NO.
71-6624

60-5924 LR ON/OFF CONTROL KNOB

23-6626 PTFE GUARD RING[†]

40-6627 GUARD RING LOADING SPRING[†]

23-5672-E SPACER CLAMP RING (ON-OFF SIDE)[†]

60-5922 TSV1 KNOB ANTI LIGATURE SHROUD

44-5406 LEFT TURN CERAMIC

5765 TSV1-3 ASSEMBLED BODY

5138 H15 FLUSHING KIT

4411 SEAL REMOVAL TOOLKIT

ALSO AVAILABLE:

- 4638 - SEALS KIT (CONTAINS PARTS MARKED WITH *)
- 4639 - SPARES KIT (CONTAINS PARTS MARKED WITH * AND **)
- 6639 - LR CLAMP RING SPARES (CONTAINS PARTS MARKED WITH †)

ALL DIMENSIONS IN mm. DIMENSIONS ARE APPROXIMATE AND PROVIDED FOR INFORMATION PURPOSES ONLY. DO NOT SCALE.	Description: TSV1-3 - LR VALVE SPARES		
	Product: ALUMINIUM SHOWER PANEL		
	Drawing Number: TSV1-3-C Drawn By: CE	Rev: A Drawn Date: 12/02/25	
	Copyright 2025, Horne Engineering Ltd. All reproduction prohibited unless authorised in writing. This drawing contains confidential and proprietary information of Horne Engineering Ltd. and unauthorised disclosure is strictly prohibited.		

TO REMOVE FLOW REGULATOR

- 1> REMOVE THE 2 CAPHEAD SCREWS
(USING 3MM HEX KEY)
- 2> PRISE SPRAYPLATE OUT WITH A BLADE
OR SIMILAR
- 3> REMOVE THE RETAINING RING
- 4> REMOVE FLOW REGULATOR WITH
ITS O-RING

STEPS <3> AND <4> CAN BE DONE
BY TURNING ON THE WATER SUPPLY AND
CATCHING THE PARTS IN A BUCKET

TO RE-FIT FLOW REGULATOR

- 1> INSERT FLOWREG INTO HOLE, FLANGED
SIDE UP (FACING THE WATER SUPPLY)
- 2> PUSH O-RING INTO GAP AROUND
FLOWREG
- 3> INSERT RETAINING RING
- 4> FIT THE LARGE O-RING ONTO THE
SPRAYPLATE AND FIT THE SPRAYPLATE
- 5> RE-FIT THE CAPHEAD SCREWS

NOTE THAT THE SPRAY PLATE CAN BE
FITTED IN 2 DIFFERENT ORIENTATIONS
TO ALLOW GREATER OR LESSER 'THROW'
OF THE WATER.

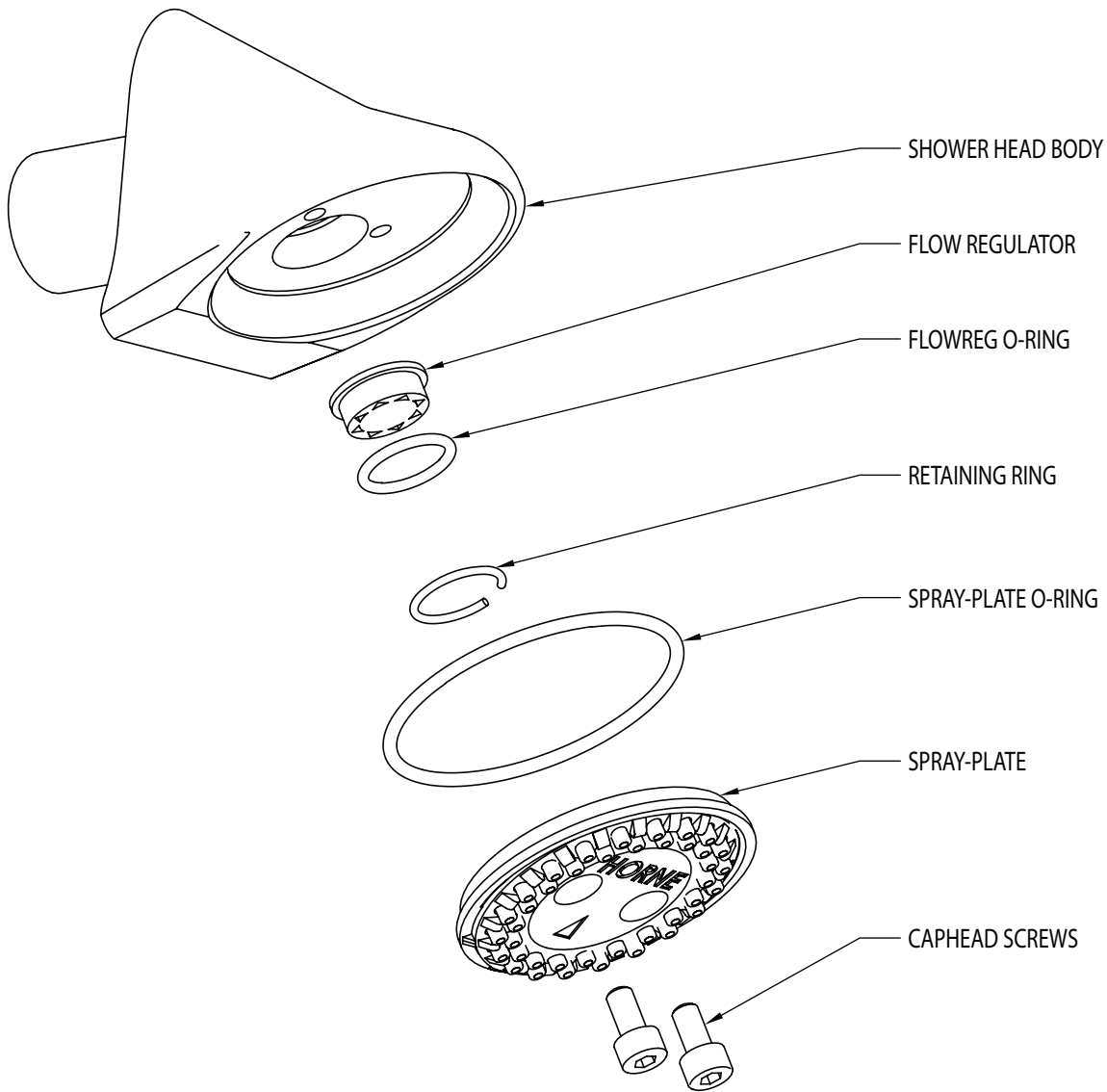

COPYRIGHT 2012, HORNE ENGINEERING LTD. ALL REPRODUCTION PROHIBITED UNLESS AUTHORISED IN WRITING

PART : REMOVAL / REPLACEMENT OF FLOW REGULATOR (VANDAL RESISTANT HEAD)	PRODUCT : HORNE SHOWER PANELS	MATERIAL : MATERIAL SPECIFICATION		HORNE ENGINEERING LTD. JOHNSTONE RENFREWSHIRE
		SCALE	DO NOT SCALE	
		DRAWN	MJ (18/11/2013)	
		CHECKED		DR'G. No. 10393
ISSUE	2			

INSTRUCTIONS SPECIFIC TO SHOWER UNITS WITH RISER RAIL

TO ADJUST STIFFNESS OF ROTATING HANDSET HOLDER...

PRISE DECAL COVER OFF HERE

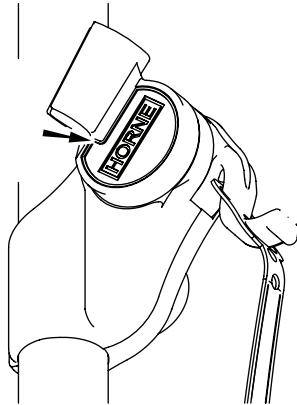

USE 3MM HEX KEY TO TIGHTEN OR LOOSEN THIS SCREW.

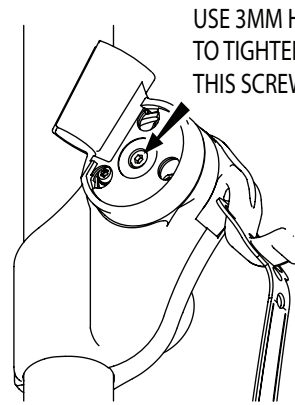

TO FIT THE DESCENDER (FOR ACCESSIBILITY)

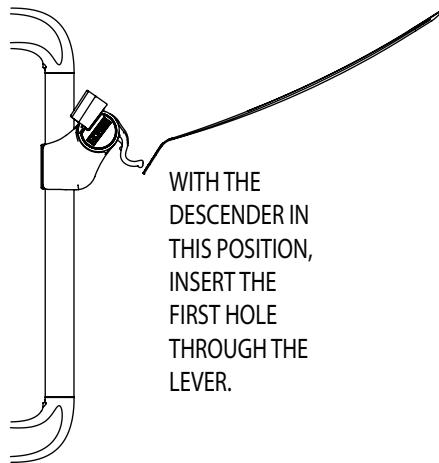

WITH THE DESCENDER IN THIS POSITION, INSERT THE FIRST HOLE THROUGH THE LEVER.

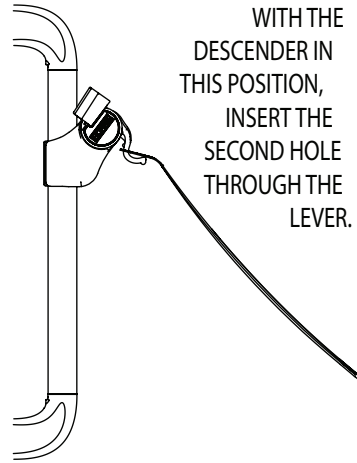

WITH THE DESCENDER IN THIS POSITION, INSERT THE SECOND HOLE THROUGH THE LEVER.

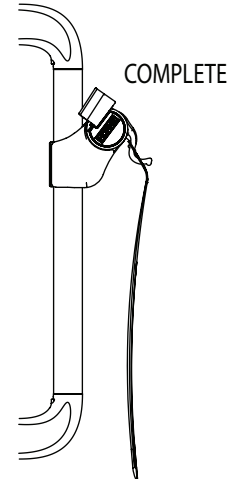

COMPLETE

TO REMOVE HANDSET HOLDER FROM THE RAIL, FIRST REMOVE DECAL COVER (SEE ABOVE), THEN USE TORX T15 DRIVER TO REMOVE THE 3 SCREWS AND THE ROTATING STIRRUP. REMOVE SCREW-COVER* AND SCREW FROM REVERSE OF HANDSET HOLDER, THEN INSERT A 50MM LONG X 3MM DIAMETER ROD (SCREWDRIVER) INTO THE HOLE AS SHOWN. HANDSET HOLDER WILL THEN SPLIT APART AND CAN BE REMOVED FROM THE RAIL.

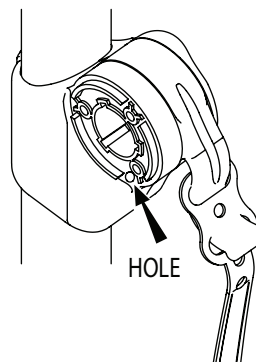

HOLE

MAXIMUM LOADINGS FOR THE SHOWER RAIL (WHEN USED AS A GRAB-RAIL):-

LENGTH BETWEEN MOUNTING CENTRES	MAX. LOAD
0.8 M	120Kg
0.675 M	150Kg
0.39M	200Kg
0.29M	200Kg

* DRILL A SMALL HOLE THOUGH SCREW-COVER TO REMOVE IT.

HORNE ENGINEERING LTD.
JOHNSTONE
RENFREWSHIRE

DR'G. No. 11399

COMMISSIONING, MAINTENANCE & IN-SERVICE TESTING RECORD

Establishment:			
Type of Valve: Horne TSV1-3 Shower Valve	Date Installed:	Installed by:	
Location of Valve:			
Commissioning Details [Fill in ALL information during commissioning]			
Hot Water Supply :	HW Temp °C	HW Pressure Bar	Temp: Instrumentation: Pressure:
Cold Water Supply:	CW Temp °C	CW Pressure Bar	
Mixed Temp at max draw-off:	Mixed Temp: °C	Flowrate at max draw-off: l/min	
Mixed Temp at low draw-off:	Mixed Temp: °C	Flowrate at low draw-off: l/min	
Instrumentation Used:	Temp:	Press:	Flow:
Cold Water Isolation Test	Max Mixed Water Temp during CW Isolation test: °C		Mixed Water Temp on restoration of CW Supply: °C
Comments: Note: MWT should return within 2 degrees of set temp, and be no greater than 43°C after this test.			

In-Service Testing Record

Establishment: Location of Valve:
 Date: Type of Valve : TSV1-3 Shower Valve

Hot Water Supply :	HW Temp	°C	HW Pressure	Bar	Instrument used (temp):	
Cold Water Supply:	CW Temp	°C	CW Pressure	Bar	Instrument used (pressure):	
Mixed Temp at max draw-off:	Mixed Temp:	°C	Flowrate at max draw-off:	l/min		
Mixed Temp at low draw-off:	Mixed Temp:	°C	Flowrate at low draw-off:	l/min		
Instrumentation Used:	Temp:		Press:	Flow:		
Cold Water Isolation Test	Max Mixed Water Temp during CW Isolation test: °C		Mixed Water Temp on restoration of CW Supply: °C		MWT should return within 2 degrees of set temp, and be no greater than 43°C after this test.	

Comments: Recommended Date of Next In-Service Test:

In-Service Testing Record

Establishment: Location of Valve:
 Date: Type of Valve : TSV1-3 Shower Valve

Hot Water Supply :	HW Temp	°C	HW Pressure	Bar	Instrument used (temp):	
Cold Water Supply:	CW Temp	°C	CW Pressure	Bar	Instrument used (pressure):	
Mixed Temp at max draw-off:	Mixed Temp:	°C	Flowrate at max draw-off:	l/min		
Mixed Temp at low draw-off:	Mixed Temp:	°C	Flowrate at low draw-off:	l/min		
Instrumentation Used:	Temp:		Press:	Flow:		
Cold Water Isolation Test	Max Mixed Water Temp during CW Isolation test: °C		Mixed Water Temp on restoration of CW Supply: °C		MWT should return within 2 degrees of set temp, and be no greater than 43°C after this test.	

Comments: Recommended Date of Next In-Service Test:

Pipe Cover Kit for Aluminium Shower Panels with In-Line Thermal Disinfection Unit (ILTDU) Fitted INSTALLATION INSTRUCTIONS

Installation requirements and specifications

Note that this Pipe Cover Kit is ONLY suitable for the Horne Range of **Aluminium** Shower Panels.

There are two different lengths of Pipe Cover Kit available for Aluminium Shower Panels – 465mm long and 940mm long. Please ensure that you have the appropriate length for your application.

Ensure that you have been supplied with the correct Pipe Cover Kit and that the Pipe Cover is long enough to fully cover the gap between the panel and the ceiling.

Fit the Aluminium Shower Panel to the wall in accordance with the Installation Instructions supplied.

Identify the components of the pipe cover kit by comparing the contents with the drawing shown on Page 4.

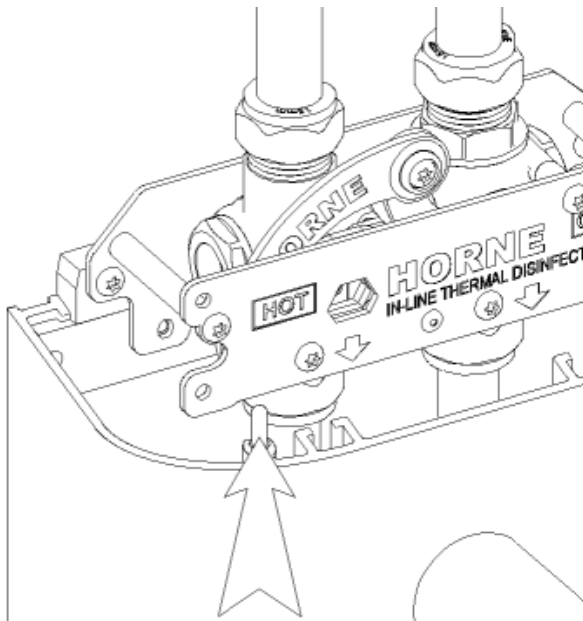

Fig. 1

Put the two Alignment Pins into the circular recesses in the Channel Section of the Shower Panel. See Fig. 1.

Place the silicone Interface Gasket onto the top of the Shower Panel, noting that it only fits one way, and that the rectangular guides engage with the rectangular recesses in the Channel Section of the Shower Panel. See Fig. 2.

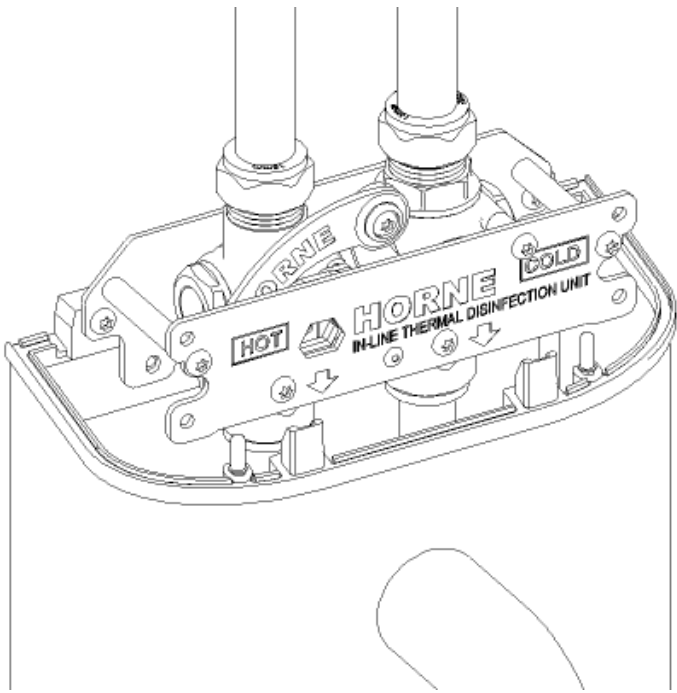

Fig. 2

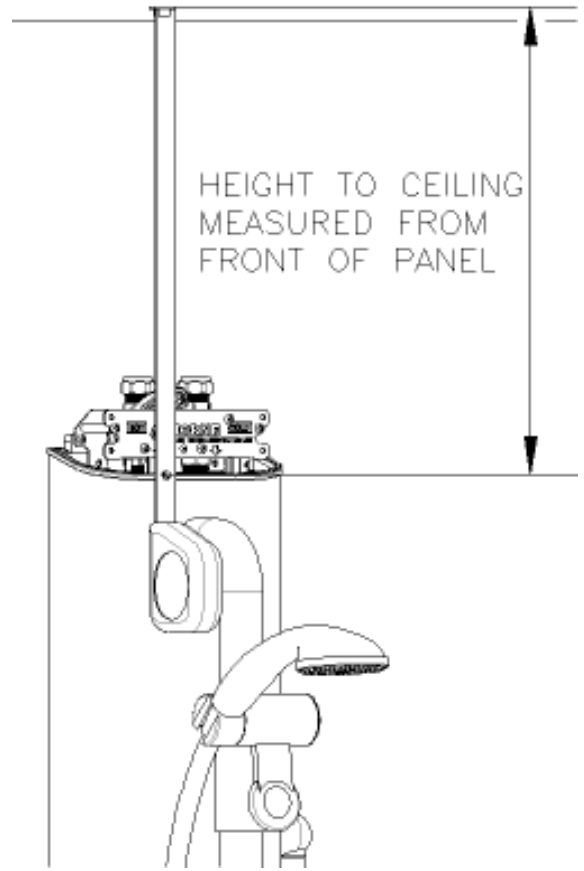

Fig. 3

Slide the Pipe Cover down into place, engaging with both the Alignment Pins and the Interface Gasket. If there are multiple cover sections, this should be repeated, ensuring the bottom section includes the key hole for ILTDU operation and leaving the section with the 90° end cut closest to the ceiling. If the Pipe Cover(s) is too long to do this, then measure the distance between the ceiling and the panel and cut the square **TOP** end of the Pipe Cover to make the Pipe Cover 15mm **SHORTER** than the measured distance, using a saw suitable for use with aluminium. See Fig. 3 and 4.

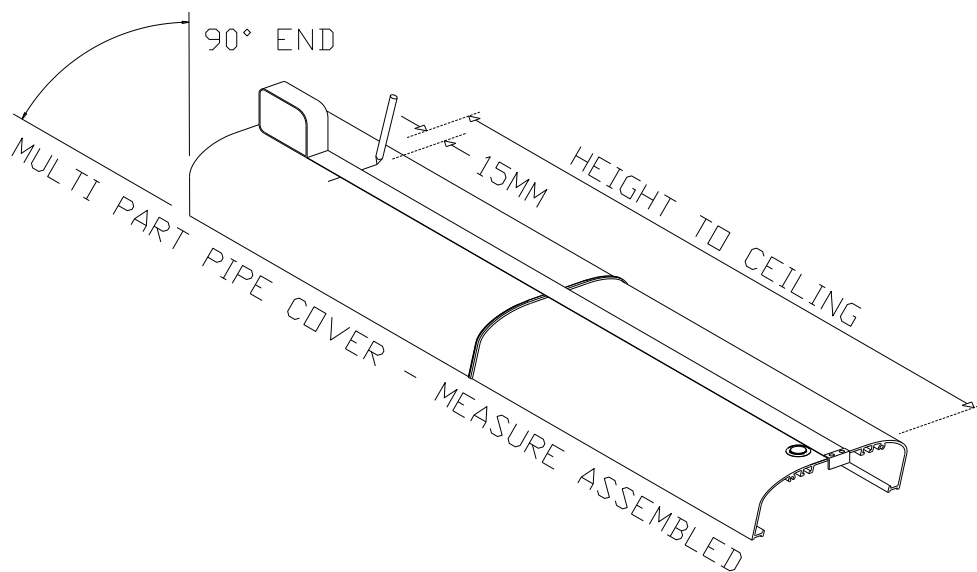

Fig. 4

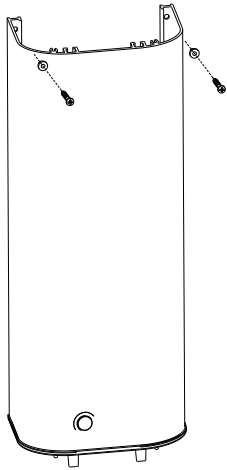

Fig 5.

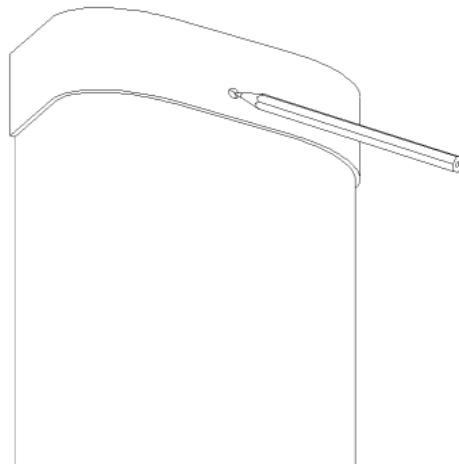

Fig 6.

For multi-section pipe covers, the intermediate lengths should be secured to the wall using the mounting holes available at the angled top cut.

Install the lowest section with gasket and alignment pins, atop the mounted shower panel. Mark off the mounting points and then secure the lower cover portion to the wall with supplied screws and bushes, using wall plugs where necessary. See Fig. 5

Slide the Pipe Cover (or top sections thereof) down into place and check for fit. The top of the Pipe Cover should be approx. 15mm from the ceiling when pressed firmly into place. Position the Saddle over the top of the Pipe Cover and against the ceiling with the hole in its lower position. Mark through the hole in the Saddle onto the Pipe Cover. See Fig. 6.

Remove the Saddle and drill the Pipe Cover with a 7 mm drill where marked. See Fig. 7.

Replace the Saddle and Pipe Cover and put in the screw to mark the wall. Ensure the mark made, **is with the screw perpendicular to the panel**. If appropriate, drill the wall to take the screw, or fit appropriate wall plugs. **N.B. Make sure that no debris enters the ILTDU during this if the pipe drops have not been installed.**

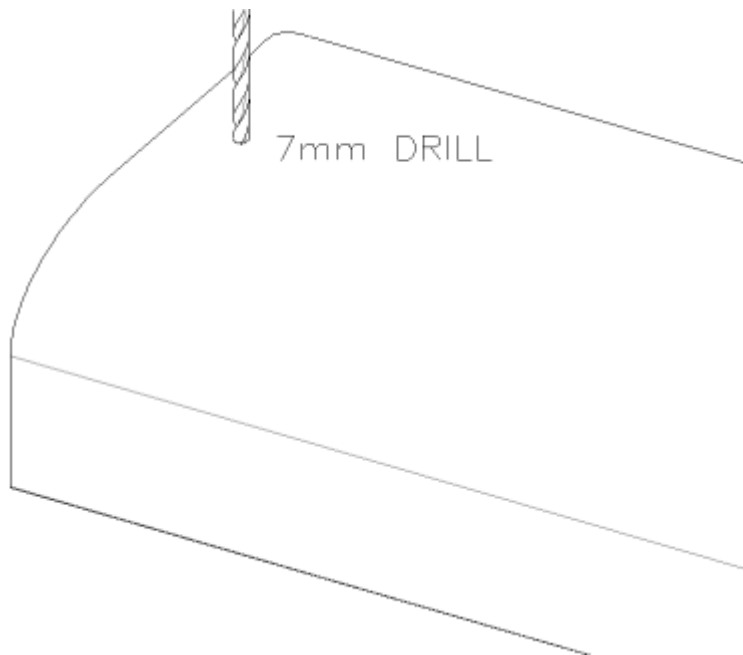

Fig. 7.

Finally, assemble the saddle to the cover by putting the Pin-Torx Security Screw through the Screw Cup, Saddle and Pipe Cover. **Do not over-tighten the Pin-Torx screw or the Saddle edges will splay out and give a poor appearance.** Silicone sealer can be used at the joint edges if required.

The drawing on Page 4 shows the exploded assembly view of the Pipe Cover and Saddle installation. *Note that pipe cover assemblies with multiple sections, will have multiples of some of the items listed.*

OPERATING INSTRUCTIONS ADDENDUM

In-Line Thermal Disinfection Unit (ILTDU) Integrated with Horne Thermostatic Shower Panels.

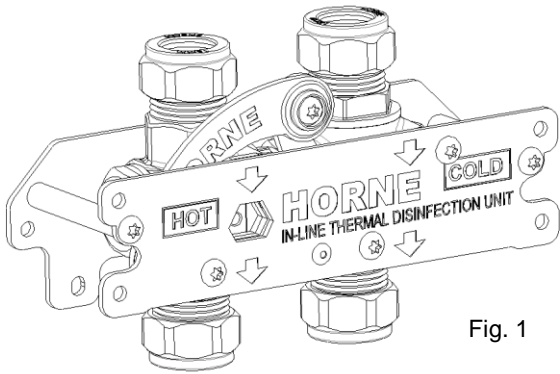

Fig. 1

Overview

The HORNE In-Line Thermal Disinfection Unit (ILTDU), shown in Fig.1, when supplied as an integrated component within a Horne shower panel, provides a simple and convenient way to pass hot water, at system hot water temperature through the entire product, in order to thermally disinfect all downstream pipework and fittings up to and including the shower outlet.

When integrated as part of a Horne shower panel, the ILTDU is mounted on top of the panel, and is concealed when the supplied ILTDU specific pipe cover is installed. Actuation with the operating key is facilitated by an access hole in the pipe cover, so there is no requirement to remove it for the disinfection operation. A safety blanking plug is supplied to cover the access hole (Part No. 71-6568); it is removed with the Magnet accessory (Part No. 43-6569) when thermal disinfection is to be undertaken.

- **LOCAL RISK ASSESSMENT SHOULD ALWAYS PREVAIL IN DICTATING THE PARAMETERS FOR DISINFECTION.** In absence of this, a hot water temperature of 60.0°C or greater, and duration of at least 10 minutes may be used as a starting point. Disinfection efficacy reduces significantly at temperatures below 60.0°C. Calibrated thermometers are a necessity.

How it works

The HORNE ILTDU directs system Hot & Cold Water to the corresponding Hot & Cold inlets of a mixing device, when in “passive” mode. However, when deliberately switched to “Disinfecting mode”, the ILTDU re-directs HOT water to the COLD inlet of the mixing device, via the interconnecting COLD pipework. This bypasses the temperature control function of thermostatic devices, allowing HOT water to flow from the outlet at elevated temperature. This disinfects all system components and pipework between the ILTDU and the water outlet.

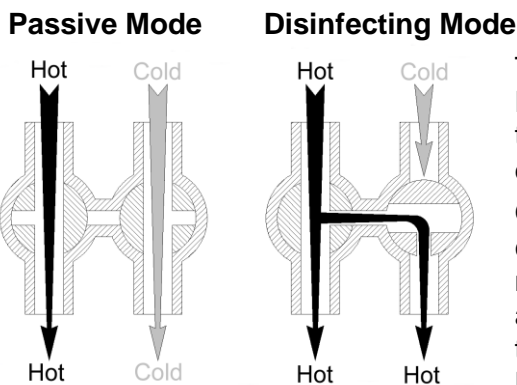

Fig. 2

The HORNE ILTDU has two operating modes – PASSIVE and DISINFECTING (Fig. 2). In PASSIVE mode, the ILTDU passes the hot and cold water supplies straight through to the mixing device and the mixing device operates normally.

Only the Horne ILTDU specific OPERATING KEY (Part No 6236) can be used to switch between PASSIVE and DISINFECTING modes. A single clockwise half turn of the OPERATING KEY activates DISINFECTING mode. This synchronously operates two 3-way ball valves to divert the hot water supply to both the HOT and COLD outlets of the HORNE ILTDU.

The outlet is run and this rapidly results in the pipework downstream of the HORNE ILTDU, the mixing device and the Outlet Fitting all being raised to system hot water temperature.

WARNING: Scalding water at system hot water temperature will discharge from the outlet fed by the mixing device during disinfection and so suitable safety precautions must be taken to reduce the risk of scalding, or damage to sanitary ware, etc.

The OPERATING KEY is specially shaped and interlocked such that it cannot be removed from the ILTDU while the ILTDU is in DISINFECTING mode. The OPERATING KEY has a large red warning triangle chained on to it. This serves as a local visual reminder on the ILTDU that it is being used in DISINFECTING mode

and that safety precautions should be taken. A replacement key should be sought if the warning triangle is missing.

After passing hot water through the mixing device for the desired period, the OPERATING KEY is turned back to its original position and the key is removed from the ILTDU. Removal of the OPERATING KEY from the ILTDU confirms that the ILTDU is in PASSIVE mode and that disinfection has ceased.

It should be noted that disinfection is a completely separate process from cleaning, and this ILTDU only disinfects components using system hot water. An elevated velocity flush should also be undertaken to help clean the treated system and get rid of any loosened biofilm.

Connect up the supplies, Leak-Test, and Commission the ILTDU

Ensure that the installation is free from leaks and then commission the ILTDU as follows:

- Check that the ILTDU is connected exactly as shown in Fig. 3. It is essential for correct operation that the supply and outlet connection indications are observed.
- *Before* inserting the OPERATING KEY, open the supplies and run the outlet until normal temperature at the outlet is reached. Measure and record this temperature.
- Insert the OPERATING KEY into the ACCESS SLOT on the ILTDU front plate through access hole in the pipe cover, removing the pipe cover keyhole safety plug with a magnet (Part No. 43-6569) where necessary.
- Turn the OPERATING KEY exactly a half turn clockwise, until you feel the mechanism reaching the end stop. The short leg of the OPERATING KEY should now be pointing upwards (towards the supply pipework).

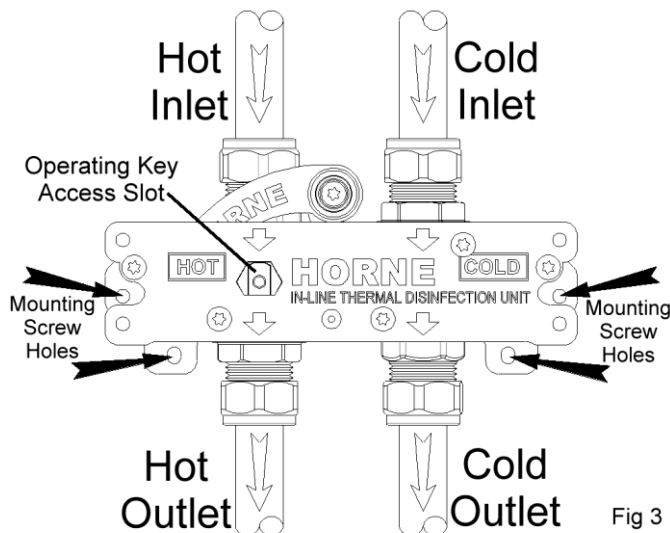

end stop. The short leg of the OPERATING KEY should now be pointing upwards (towards the supply pipework).

- The OPERATING KEY cannot be removed from the ILTDU in this position. This is intentional, to prevent the ILTDU from being accidentally left in the DISINFECTING MODE.

- Measure the water temperature at the outlet and ensure that it is at system hot water temperature. **Note that if the hot water system cannot achieve 60.0°C, it is unlikely that effective disinfection will be achievable within a reasonable timescale.**

- Turn the OPERATING KEY back half a turn anti-clockwise against the end stop, remove the key and replace the safety plug, if fitted. Ensure that the temperature at the outlet rapidly returns to the set temperature recorded prior to disinfection.
- Perform a cold water isolation test on the shower to ensure that it is still providing scald protection.
- ALWAYS remove the OPERATING KEY from the HORNE ILTDU when the device is in the PASSIVE MODE. Do NOT leave the OPERATING KEY in the device when in PASSIVE mode.

The HORNE ILTDU is now commissioned.

Using the HORNE ILTDU

Before the ILTDU is used, a local risk assessment should be undertaken to establish:

- Any bacterial load present and the most appropriate time/temperature regime to deal with it.
- The scalding risk and how to minimise it during disinfection.
- Any necessary precautions to protect sanitaryware from the hot water.
- The most appropriate frequency for a disinfection routine to be scheduled.

The use of the HORNE ILTDU as integrated with a HORNE Shower Panel will now be described.

- Ensure that the Hot Water Temperature available is consistent with that recommended by the local risk assessment. Note that a **minimum of 60.0°C** is normally required for disinfection.
- Ensure that no unauthorised or vulnerable people are able to access the shower while the disinfection process is underway.
- Perform a cold water isolation test on the shower panel being disinfected. If the cold water isolation test is satisfactory then proceed with the disinfection procedure. If the TMV does not pass the test, then address that, before proceeding, by following normal maintenance procedures for the TMV. These are described in the Instructions for the Shower Panel.
- Fully turn on the shower, and then insert the OPERATING KEY into the HORNE ILTDU, removing the pipe cover keyhole safety plug with a magnet (Part No. 43-6569) where necessary. Turn the OPERATING KEY one half turn clockwise, against the end stop. The OPERATING KEY will remain in the HORNE ILTDU during this time – it cannot be removed.
- The red warning triangle attached to the OPERATING KEY serves as a highly visible reminder that the ILTDU is in DISINFECTING MODE. For this reason, do not use the OPERATING KEY without the warning triangle attached.
- **Note: Do NOT remove the Shower Hose or the Shower Handset during thermal disinfection; it is vital that each of these parts is fully thermally disinfected.**
- **Thermal disinfection should be applied to all wetted components to be effective. If any kind of filter is fitted to the outlet, advice should be sought from the filter manufacturer as to whether their product can withstand appropriate disinfection temperatures.**
- Measure the temperature of the water coming out of the shower head. This should rise to system hot water temperature. When it reaches the minimum temperature recommended by the local risk assessment, start timing, and permit the water to run for the required duration. Measure the temperature during this time to ensure that the temperature is maintained at the required high level. If the temperature does not reach the required level, or is not maintained at the required level, stop the process and address the water temperature. Satisfactory disinfection cannot be assured otherwise.
- After the water has run for the required time at the required temperature, turn the OPERATING KEY one half turn anti-clockwise back to its original position, again against the end stop; remove the key and replace the safety plug, if fitted. Always remove the OPERATING KEY whenever the ILTDU is returned to the PASSIVE mode. Do not leave the OPERATING KEY in the ILTDU when it is in PASSIVE mode.
- Let the shower run for a few minutes and monitor the temperature to make sure the water temperature returns to a safe and comfortable limit.
- Perform a cold water isolation test on the TMV and ensure that it closes off the hot water supply, and is thus still capable of preventing scalding, then check that the correct mixed water temperature is re-established. If the TMV does not pass the cold water isolation test, perform regular maintenance operations on the TMV, and do not allow use of the shower panel until the TMV satisfactorily prevents hot water flow on isolation of the cold inlet.
- Record the parameters of the disinfection process on a record sheet (see page 8 of this document, or download a customisable sheet from www.horne.co.uk)
- Note that disinfecting is a separate process from cleaning. This process will disinfect the TMV and pipework, but will not, in itself, clean the system. It is advisable to perform an elevated velocity flushing procedure, using an appropriate Horne Flushing Kit for the Shower, to encourage the reduction of biofilm and debris if present. The use of a Horne Flushing Kit permits full-bore flushing and bypasses flow regulators within the panel in order to achieve the maximum water velocity possible.

Maintenance

The HORNE ILTDU has no user serviceable parts, and does not require any ongoing maintenance, other than occasional cleaning and lubrication of the metal link mechanism with SILICONE oil, to prevent friction in operation. If the ILTDU fails to work properly, it should be replaced. No attempt should be made to disassemble the ILTDU.

If the OPERATING KEY is lost, do not attempt to operate the ILTDU without it. It will not operate satisfactorily, the ILTDU could be damaged, and it is dangerous. Replacement Keys (Part No 6236) can be ordered from Horne Engineering Ltd (contact details on front cover).

The Horne ILTDU is patented. EU Patent No. EP2948716

**RECORD SHEET for HORNE In-Line Thermal Disinfection Unit (ILTDU)
(Integral to Horne TSV1 Shower Panel)**

In-Service Usage Record			
Establishment: Location of ILTDU: Shower Outlet protected:			

Date:	Facilities Operator	Elevated velocity flush carried out too?	Yes/No
Temperature measured at outlet during thermal disinfection:°C	Duration of thermal Disinfection: mins	cfu count before use: (if appropriate)	cfu count after use: (if appropriate)

Date:	Facilities Operator:	Elevated velocity flush carried out too?	Yes/No
Temperature measured at outlet during thermal disinfection:°C	Duration of thermal Disinfection: mins	cfu count before use: (if appropriate)	cfu count after use: (if appropriate)

Date:	Facilities Operator:	Elevated velocity flush carried out too?	Yes/No
Temperature measured at outlet during thermal disinfection:°C	Duration of thermal Disinfection: mins	cfu count before use: (if appropriate)	cfu count after use: (if appropriate)

Date:	Facilities Operator :	Elevated velocity flush carried out too?	Yes/No
Temperature measured at outlet during thermal disinfection:°C	Duration of thermal Disinfection: mins	cfu count before use: (if appropriate)	cfu count after use: (if appropriate)

Date:	Facilities Operator :	Elevated velocity flush carried out too?	Yes/No
Temperature measured at outlet during thermal disinfection:°C	Duration of thermal Disinfection: mins	cfu count before use: (if appropriate)	cfu count after use: (if appropriate)

Date:	Facilities Operator :	Elevated velocity flush carried out too?	Yes/No
Temperature measured at outlet during thermal disinfection:°C	Duration of thermal Disinfection: mins	cfu count before use: (if appropriate)	cfu count after use: (if appropriate)