



Horne Engineering Ltd
 Rankine Street
 Johnstone PA5 8BG
 Tel: 01505 321455
 technical@horne.co.uk
 www.horne.co.uk

HORNE TIMED FLOW CONTROL THERMOSTATIC SHOWER PANEL FOR SURFACE MOUNTING

INSTALLATION, COMMISSIONING & MAINTENANCE INSTRUCTIONS

These instructions (L-84) cover the HORNE range of pre-plumbed shower panels with PUSH-BUTTON flow control ONLY. There are separate instructions for panels with push-button flow control and a rotary knob for temperature control (L-178), and also for those with dual rotary controls (L-180, L-189).

0.1 Approvals

This range of Horne shower panels features an integral Horne-15 TMV, which is independently tested & approved by an ISO 17025 Accredited Test House to all the requirements of Department of Health - HTM 04-01: Supplement Performance Specification D 08: Thermostatic Mixing Valves (Healthcare Premises), to the following designations and for the following applications:

HP-S	Shower with supply pressures of 1 – 5Bar and unrestricted flow rate
LP-S	Shower with supply pressures of 0.2 – 1Bar and unrestricted flow rate

It also complies with Regulation 4 of the Water Supply (Water Fittings) Regulations 1999.

0.2 Backflow Prevention

The hot and cold inlets to the Horne-15 valve are fitted with single in-line Reg 4 approved DN15 Check Valves.

0.3 Supply Water Pressure Requirements

The minimum water pressure required to achieve a spray at the spray head is a dynamic head of 5m (8 psi, 0.5Bar) at the spray head.

Note that dynamic head is measured with the water running.

Where the shower panel is fed by supplies with differing pressures, a pressure-reducing valve (PRV) may be required on the inlet with the higher pressure. If the lower inlet pressure is low enough (typically lower than 1Bar dynamic) that the flow-regulator in the outlet fitting (see pages 11-13) can be removed, then a PRV should not be required. If the lower of the 2 supply pressures is higher than around 1Bar, then a flow-regulator will likely be required to control flow. If the flow-regulator is installed, and the supply pressures are substantially unbalanced, then a PRV could also be needed to prevent pulsing of the flow. Although this has minimal effect on thermostatic control, the flow pulsing is often considered undesirable.

Note that output flowrate is always determined by the lower of the two inlet pressures.

0.4 Operating Conditions Required for TMV Type 3 Compliant Installations

	Low Pressure	High Pressure
Maximum Static Pressure	10Bar	10Bar
Flow Pressure, Hot & Cold	0.5-1Bar	1 to 5Bar
Hot Water Supply Temperature	55 – 65°C	55 – 65°C
Cold Water Supply Temperature	5 – 20°C	5 – 20°C
Minimum Temperature Differential (Hot/Mixed, Mixed/Cold)	5K (=5°C)	5K (=5°C)

OUTSIDE THESE CONDITIONS OF USE VALVES CANNOT BE EXPECTED TO OPERATE AS TYPE 3 VALVES.

0.5 Temperature Adjustment Range

The mixed water temperature can be adjusted from cool through to a top limit (which can be preset during installation – factory set to approx. 41°C - with full anti-scald protection throughout the range).

0.6 Water and Energy Conservation

Horne shower panels are fitted at the factory with flow regulators at the shower outlet to reduce the flow rate and conserve water and energy. The drawings at the end of this document provide information for accessing the flow restrictors/regulators for removal or replacement.

0.7 Alternative Water Entry

Note that panels with rear water-entry, with flexible soft-PEX hoses are also available. More specific instructions for installation of these panels is given at the end of the installation section.

0.8 Adjustment of Flow Duration

The Timed Flow Control Cartridge supplied with all variants has an adjustable duration, and is factory set to 45 seconds (maximum duration). This is adjusted using the supplied Hex Key through the hole in the front of the Push-button. See Drawing PA713 on pages 15-16.

SECTION 1: INSTALLATION

The surface mounting enclosure is supplied with fixings to attach it to a wall. However, consideration should be given to the type of wall fittings required, as different substrates will require different fittings. It is the responsibility of the installer to ensure that the fixings used are appropriate for the wall substrate.

The hot pipe is on the left, and cold on the right, when viewed from the user's perspective.

1.1 Recommended Mounting Heights – Guidance Only

T109 / T307 Panel	Support screw should be 2.0 metres from finished floor level*.
T306 Panel (swivel-head, shown page 13)	Support screw should be 2.1 metres from finished floor level.

* For accessible and Changing Places installations, please refer to Building Regulations Doc M and BS8300 for appropriate guidance.

1.2 Mark the position for the panel

Identify a suitable position for the pre-plumbed enclosure and mark a spot for the support screw on the wall on the centreline of where the panel is to go, at the height indicated in the table above.

1.3 Install the Support Screw

Drill a hole in the wall and insert a wall plug and screw (7mm hole if using the supplied plug), leaving the head of the screw protruding approximately 12mm from the wall. Note that a corrosion resistant stainless-steel screw is supplied for this purpose.

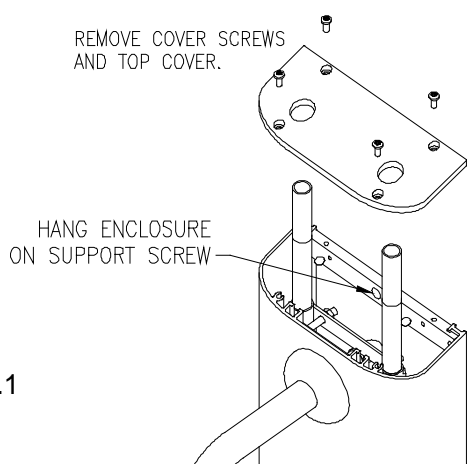

Fig.1

1.4 Hang the Enclosure on the Support Screw

Except where the panel includes an integral ILTDU, release the top cover of the pre-plumbed enclosure by removing the four screws. Hang the pre-plumbed enclosure on the support screw by the larger hole in the middle of the back strap and let this take the weight of the enclosure.

1.5 Mark out the Four Support Holes

Ensure that the enclosure is hanging true and then mark out the holes for the 2 upper support screws. Remove the bottom cover of the pre-plumbed enclosure and mark out the 2 lower support screws (See Fig. 2).

1.6 Drill Support Holes

Carefully remove the pre-plumbed enclosure from the temporary support screw and, being careful not to scratch the enclosure or its covers, lay it down where it will not be damaged. Drill 4 x support holes (7mm for the supplied plugs) to mount the panel.

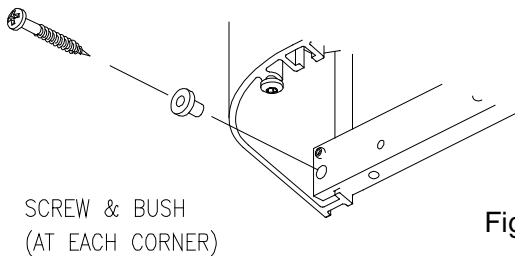
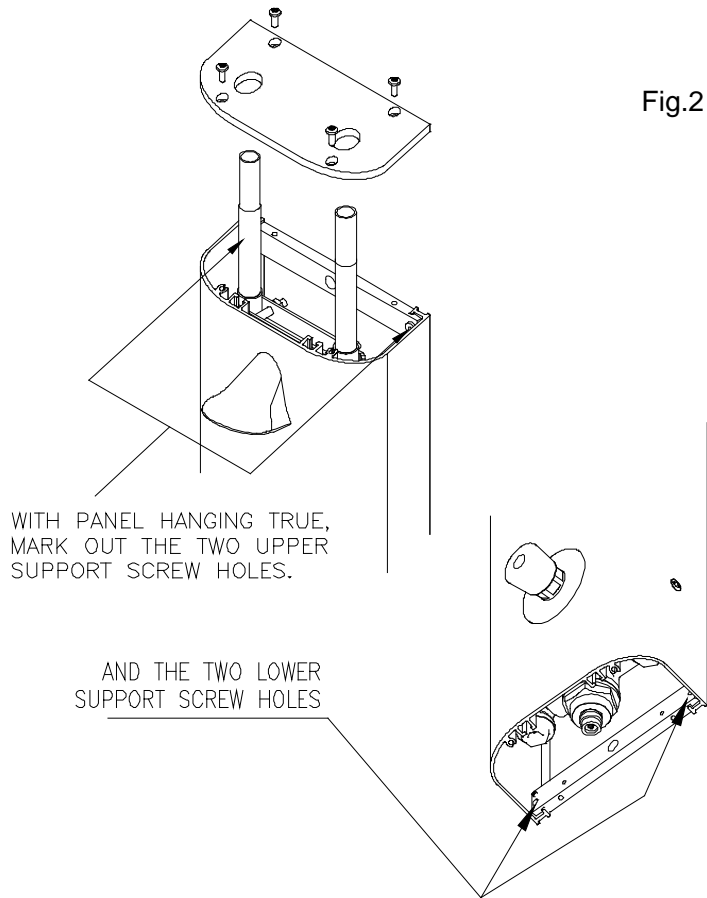

1.7 Attach the Unit to the Wall

Carefully re-hang the pre-plumbed enclosure on the temporary screw. Put the 4 supplied screw bushes in the mounting holes in the panel and then attach the panel firmly to the wall using 4 stainless-steel screws. A bead of silicon mastic can be used, if required, to cover any gaps behind the panel on uneven walls. Do not mastic the lower End Cap to the wall.

N.B. It is important to use the supplied screw bushes.

1.8 Connect the Supply Pipes

N.B. Except where the panel includes an integral ILTDY, ensure that the top cover of the pre-plumbed enclosure is replaced prior to connecting up the supply pipes. The fitting of isolation valves is required as close as practicable to the water supplies inlets of the shower panel.

Connect the hot water supply to the left-side inlet, and cold water to the right-side inlet (See Fig. 4).

DO NOT OPEN THE WATER SUPPLIES AT THIS STAGE AS THEY HAVE NOT BEEN FLUSHED OUT TO REMOVE THE DEBRIS IN THE PIPEWORK. SUCH DEBRIS CAN DAMAGE THE THERMOSTATIC VALVE

1.9 Flush the Pipework

Flush out the pipework in accordance with Water Bylaws 2014 (Scotland) and BS EN 806. The use of a Horne flushing kit is strongly recommended, because this connects directly to the water inlets to the mixing valve. See Figs. 5 and 6.

Fig.4

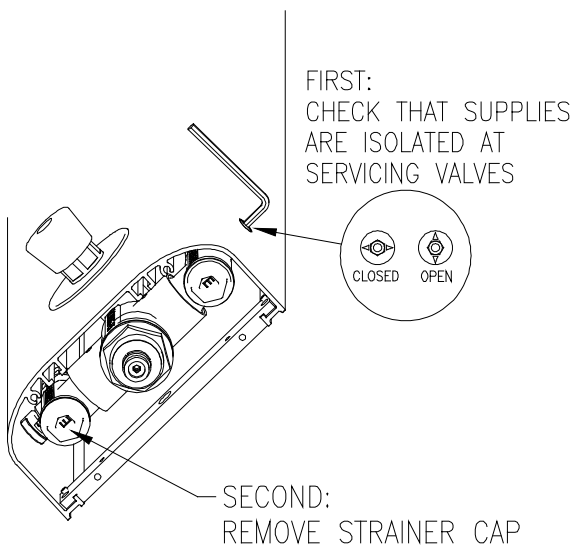
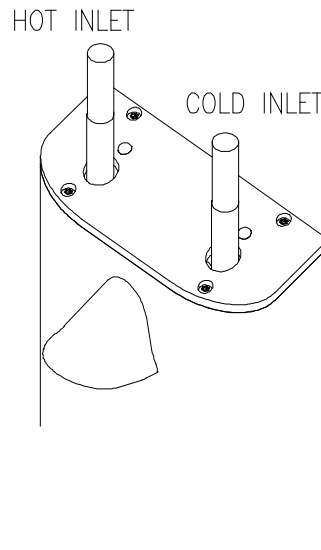

Fig.5

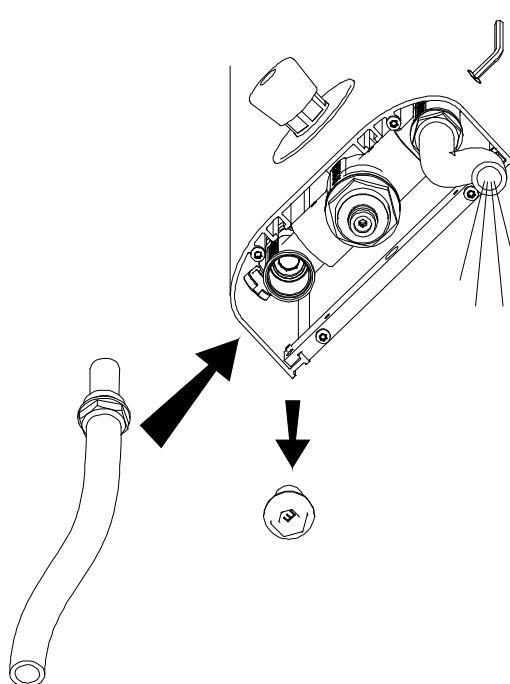

Fig. 6

Access to the flushing points is gained from underneath the casing through the lower end cap. Isolate the water using the low-level servicing valves located on the side of the panel (Fig. 5) using a 4mm hex key. Remove the strainer cap with the strainer basket and screw in the flushing adapter. Place the end of the flushing hose in a drain or container and turn on the supply to flush AT FULL BORE until any pipework which has been worked on is cleared. After flushing, remove the flushing adapter and replace the strainer cap. Repeat for both hot and cold supplies. See Figs. 5 and 6.

NOTE THAT IF THE SYSTEM IS NOT TO BE COMMISSIONED IMMEDIATELY AND/OR THERE IS ANY DANGER OF FREEZING THEN THE PIPES AND VALVE MUST BE DRAINED TO AVOID DAMAGE. OPEN THE STRAINER CAPS FOR THIS PURPOSE.

1.10 Test for Leaks in Pipework

Open the supplies and check for any leaks at the supply pipe joints. Open the servicing valves on the casing (Fig.5). Water should not flow from the spray head as the push button timed flow control has not been pressed. Make good any leaks found. The valve is now ready for commissioning.

Note that if the controls, enclosure and shower accessories require cleaning then care must be taken not to scratch them in the process. Wash off any surface dust with the shower spray before cleaning with soapy water.

DO NOT USE ANY ABRASIVE CLEANERS OR SOLVENTS OR THE SURFACES MAY BE DAMAGED.

1.11 Supplementary Installation Instructions for ...B Variants [Hose Inlets from Rear].

Horne H15-TFC shower panels are available in versions with flexible braided stainless steel inlet hoses rather than top entry copper pipework. The hoses used are UK Water Reg 4 Approved SOFT-PEX (cross-linked polyethylene). They are not EPDM lined. These shower versions have Product Reference codes with the suffix B, e.g. T306B.

The main difference, from an installation point of view, is that the water supplies may have to be connected before the pre-plumbed enclosure is attached to the wall. Accordingly, point 1.8 on the attached installation instructions (Connect the Supply Pipes) should be performed before point 1.7 (Attach the unit to the Wall) unless alternative access is available to the connections, e.g. via an access panel.

Note that the braided hose inlets are colour coded with BLUE for the Cold Water Supply and RED for the Hot Water Supply.

Care should be taken to ensure that the weight of the pre-plumbed enclosure is taken by the mounting screws and NOT by the hoses.

SECTION 2: COMMISSIONING

Commissioning the unit involves flushing the water supply; setting the temperature; and finally performing a cold-water isolation test to confirm the safe operation of the thermostatic valve as fitted. Flushing is included in the Installation section to ensure it is done as soon as possible after installation but should be considered vital to the commissioning process. Commissioning is essential to establish a reference point for future in-service tests, and to ensure the thermostatic valve works correctly under site conditions.

2.1 Flushing

Unless you are absolutely certain that this has been done, flush the pipework: see section 1.9 above.

2.2 Pre-Checks

Ensure that the NHS designation of the valve matches the intended application, that both hot and cold-water supplies are open and at, or near, their design temperatures and pressures, that they are within the requirements of the valve as outlined in section 0.4. Also ensure that the servicing valves are open.

2.3 Temperature Setting

The Horne 15 is set in the factory to verify correct thermostatic performance, but this must be checked on site during commissioning to ensure that the site conditions do not impair the operation of the valve. If necessary, reset the maximum outlet temperature to 41°C.

2.3.1 Run the shower by pushing the button. For installations with a fixed shower head, putting a burst polythene bag over the shower head will help to catch and deflect the spray during commissioning.

2.3.2 Keep the push-button depressed for as long as needed until the water temperature has stabilised. Should the temperature rise, or drop, in an uncontrolled fashion, then the hot and cold supplies are probably reversed. Correct this before proceeding.

- 2.3.3 Remove the lower end cap from the shower Enclosure by removing the four screws.
- 2.3.4 Using a 4mm (or 5/32") hex key, adjust the temperature of the mixed water. Turn the screw anticlockwise to increase the temperature, or clockwise to reduce it. See Fig.7.

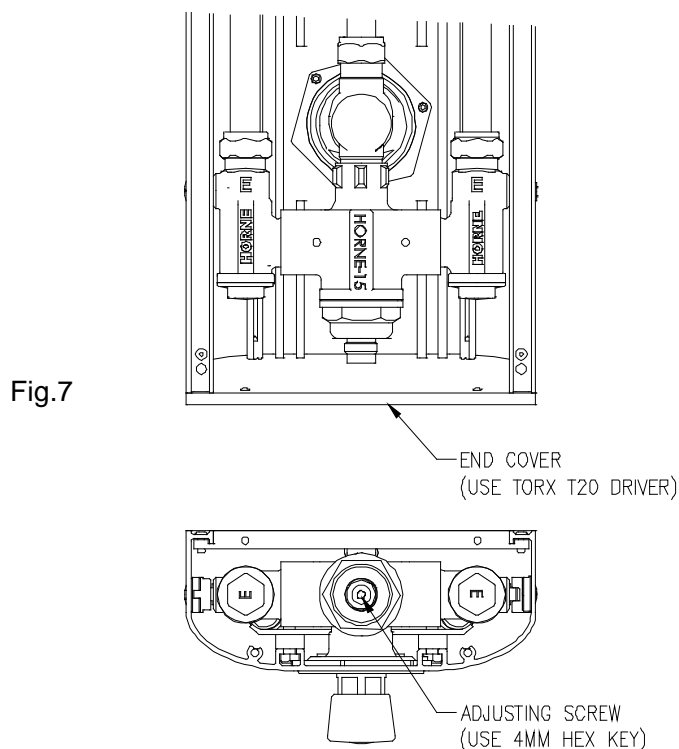

- 2.3.5 During commissioning, the valve **MUST** be adjusted **DOWN** to temperature. This is to ensure that the hot water system is capable of supplying water, at the working flowrate, in excess of the required outlet temperature by a margin of at least 5°C. Note that this is not always the case with instantaneous water-heaters. To do this, set the valve to 5°C higher than required; measure and confirm the elevated temperature, and then reduce the temperature to the required level. If the valve cannot be set to 5°C higher than required, then the outlet temperature is being controlled by the inlet conditions and not safely by the valve, therefore the commissioning is not complete, and **VULNERABLE USERS SHOULD NOT BE ALLOWED TO OPERATE THE SHOWER.**
- 2.3.6 After each adjustment, isolate the **HOT** supply at the servicing valve for a few seconds, restore it and check the set temperature.
- 2.3.7 Operate the shower a few times to ensure the set temperature is correct.
- 2.3.8 Record the commissioning details on the attached maintenance sheet (page 17 of this document) to permit the in-service performance of the valve to be assessed.

2.4 D08 Compliance

Note that, to comply with D08, the final stabilised Mixed Water Temperature should not exceed 43°C. Record the commissioning information, including equipment used, on the attached commissioning sheet to permit the in-service performance of the valve to be assessed in the future.

2.5 Cold Isolation Test

- 2.5.1 Finally, check the thermal shut-off facility of the TMV by performing a Cold Isolation Test (sometimes colloquially called a “fail-safe” test) as follows. With the shower running full, close the cold (i.e. right side) servicing valve. [The Servicing Valve is closed when the arrows are in the horizontal position, and open when they are in the vertical position: see Fig. 5]. If there is any flow after 5 seconds, this must amount to no more than 120ml in 60 seconds of collecting. If there is more than this amount, find possible corrective actions in the “Maintenance” section below. If the Cold Isolation Test is satisfactory,

restore the supply and note the final stabilised temperature in the commissioning log. This should be within 2°C of the original temperature, and must not exceed 43°C. Generally, the mixed water temperature should not rise by more than 2.9°C during this cold-water isolation test. Record the result of this on the attached commissioning sheet. Check that the button is pushed-in during the entirety of this test, or the results will be invalid (no-flow without the button pressed is not a surprise!).

Note that the incoming hot-water temperature must be maintained in the range described in the table at the bottom of page 1 for this test to be valid. Refer to the maintenance section of this booklet or phone the factory for advice, if necessary.

For installations with a fixed shower head, putting a burst polythene bag over the shower head will help to catch and deflect the spray and avoid you getting wet.

2.6 Test the Check-Valves

Although check-valve failures are rare, verifying their operation at commissioning time in a large installation can give peace of mind later. Refer to section 3.9 .

SECTION 3: MAINTENANCE

Maintenance of all Thermostatic Mixing Valves is essential to ensure the product continues to perform to specification after installation and continues to afford scald protection. Record all maintenance carried out on the attached commissioning and maintenance record sheet on page 18.

3.1 In-Service Testing

Periodic testing should be carried out to check whether any deterioration has occurred in the performance of the shower valve. The results of these tests, and the equipment used, should be recorded on the Commissioning, Maintenance and In-Service Testing Sheet at the back of these instructions. Fill in all the parameters requested on the sheet.

Note that instrumentation to the same specification should be used each time when measurements are taken to ensure consistency of results.

Also record any requirement to adjust the Mixed Water Temperature on the in-service testing record.

NOTE: A THERMOSTATIC MIXING VALVE IN NEED OF MAINTENANCE CAN BE UNDETECTABLE IN NORMAL USE AND ONLY BECOME APPARENT WHEN DISRUPTION OCCURS IN THE HOT OR COLD-WATER SUPPLY TEMPERATURES OR PRESSURES. IN SERVICE TESTING SHOULD BE CARRIED OUT AT A FREQUENCY DETERMINED BY LOCAL RISK ASSESSMENT TO DETECT ANY SUCH DETERIORATION.

3.2 Routine Servicing

- 3.2.1 Replace the “O” rings every three years (Maintenance kit with spare “O” rings available). It is especially important to replace the slide-valve seal, located in a groove in the valve body. Horne tool 4411 is helpful for this job. See the Horne website “maintenance” section for further instruction and videos.
- 3.2.2 Replace the Thermostat Element every 6 years, or more often if problems are experienced or in installations where the water is aggressive.
- 3.2.3 Replace the slide-valve assembly if it becomes damaged. This may happen due to scale or grit in the water.

3.3 Strainer Baskets

Initially check the strainer baskets for debris every three months and clean if required. This period can perhaps be increased later if it is established that the water is generally clean and free of debris.

3.4 Cold Isolation Test - Corrective Actions for Failure

- 3.4.1 Regularly perform a Cold Isolation Test and check the maximum temperature setting as described in the section 2.5 above. If the valve fails this test, then consider the following:
- 3.4.2 Perform an Isolation Test, but shut the hot instead of the cold. If this results in a similar rate of flow as when shutting the cold then consider that there may be a problem with the slide-valve seal, see section 3.2.1. Follow the routine servicing instructions below.

- 3.4.3 Opening and cleaning the valve can cure problems caused by dirt in the pipework which has migrated into the valve, but note that if water cleanliness is poor, or flushing is not carried out, then dirt can damage the slide-valve knife-edge faces. This will necessitate replacement of the slidevalve.
- 3.4.4 Cleaning/dressing of the hot valve seat may be necessary if the valve is old and/or scaled. This can be done with Horne tool 5395, and some toothpaste or fine grinding paste.
- 3.4.5 Failure of the Cold Isolation Test can be caused by hot water in the cold supply: test the check-valves.
- 3.4.6 If the water supply is 'hard', then de-scaling of the valve may be necessary. All rubber parts must be removed prior to de-scaling. See section 3.7.

3.5 Notes on Dismantling

- 3.5.1 All internal components of the thermostatic valve can be removed from the bottom of the panel by removing the components shown in drawing H15-x-C below. There is no need to remove the panel from the wall unless you wish to remove the valve from the panel, to de-scale it for example.
- 3.5.2 Treat all parts with care when removing them from the valve body. Note especially that the slide-valve is a precision component and can easily be damaged.
- 3.5.3 Do not forget the slide-valve seal, partially hidden in a groove in the valve-body. Horne tool 4411 can be used to remove it. Be careful not to scratch the groove sides whilst removing the seal. This and all other plastic/rubber parts must be removed before de-scaling.

3.6 Notes on Descaling (see drawing H15-x-C below)

- 3.6.1 If the valve body requires de-scaling, first remove the valve from the panel (see section 3.10). Remove all o-ring seals and internal parts, then use a proprietary de-scaling fluid. Do not put the thermostat element or any plastic/rubber parts in de-scaling fluid.
- 3.6.2 Inspect the condition of the "Hot Valve Face", with which the knife-edge of the slidevalve mates, and the "Cold Valve Face". If the valve faces show signs of deterioration, they can be resurfaced as follows.
 - ◇ Re-surface the Hot Valve Face using a mandrel (Horne part no. 5395) and a water-soluble scouring paste (toothpaste works quite well).
 - ◇ Use P800 Grade wet abrasive paper on a flat surface to smooth the "Cold Valve Face" (ie, the end of the cover on which the slide-valve mates).
- 3.6.3 Prior to re-assembly of the valve, ensure it is clean and all debris is removed.

3.7 Notes on Re-assembly

- 3.7.1 Make sure all components are clean before re-assembly. It is recommended to fit new o-rings.
- 3.7.2 Smear silicon oil (not grease) on all "O" rings prior to installation. Also lightly smear the outside diameter of the slide-valve with silicon oil before fitting.
- 3.7.3 Ensure the slide-valve seal is fitted in the body and is in good condition.
- 3.7.4 Fit the components into the valve body using drawing H15-x-C (below) as a guide.
- 3.7.5 For optimal thermostatic performance, orient the visible tail end of the return spring towards the left side (hot inlet side) before inserting the slide-valve.
- 3.7.6 After any dismantling of the valve, perform a Cold Isolation Test per section 2.5 to verify correct re-assembly.

3.8 Testing of Check-Valves

The Check Valves prevent crossflow between hot and cold-water supplies under unequal pressure conditions and are designed for long life with no maintenance. Their function can be tested as follows:

- 3.8.1 Start with the outlet to the valve closed and both hot and cold isolating valves open.
- 3.8.2 To test the Check Valve on the hot side, shut off the hot supply and ensure the cold supply is open. Be prepared for leakage of trapped water from the pipe and remove the strainer basket on the hot side. Any continuing leakage evident from the strainer body is likely to be coming through the hot supply Check Valve (N.B. Ensure the hot isolating valve shuts off tightly, or it may cause leakage here). Testing of the cold-side check valve is a mirror of this process.

- 3.8.3 If either Check Valve is passing, then the inlet elbow (complete with Check Valve and strainer basket) should be replaced. It is not possible to satisfactorily remove the Check Valve itself from the inlet elbow and this should not be attempted. The shower valve body must be removed from the pre-plumbed enclosure to remove the inlet elbows. Pay attention to the section below on “removal of valve from panel”, and Fig.9.

3.9 Timed Flow Control

- 3.9.1 The Timed Flow Control Cartridge supplied with all variants has an adjustable duration, and is factory set to 45 seconds (maximum duration). This is adjusted using the supplied Hex Key through the hole in the front of the push button - see drawing PA713 below.
- 3.9.2 If the duration of the timed flow control begins to shorten or lengthen significantly then this could be a sign that the cartridge requires cleaning. Over a period (or if the water supplies have not been flushed through adequately on a new installation), sediment and other particulate matter can get trapped in the Timed Flow Control and disrupt the timing.
- 3.9.3 The Timed Flow Control (TFC) cartridge can be removed for cleaning or replacement (spare parts are not available) as per drawing PA713 (pages 15-16).
- 3.9.4 NB: For -LR models, which include a conical shroud around the timed flow control cartridge, the cartridge can only be removed by removing the panel from the wall. To do this, first isolate the water supply upstream of the panel then purge the water from the internal pipework by pressing in and holding the TFC button until the flow stops. Disconnect the shower supply pipes from top entry pipework. Remove the top and bottom cover caps with a TORX T20 driver and unscrew the four wall fixings. Lift the Enclosure from its supporting screw to remove it, being sure to support its weight if rear entry supply hoses are still connected behind. Loosen the grub screws and locknut holding the LR shroud in place from behind, being careful to catch the shroud as it disengages to prevent scratching of the chromium plating. Now unscrew the TFC cartridge as per drawing PA713.

3.10 Removal of Valve from Panel

If removing the valve from the panel, for example for descaling, then care should be taken over the low-level isolation actuators, which are connected to the valve via spring-loaded Oldham couplings. The 2 parts of the coupling can be held together by M2 screws (part no 41-5667, inserted down the 4mm hex hole), which prevent loss of the very small springs during assembly & disassembly. The complete coupling is part no. 43-5663.

3.11 External Cleaning

When cleaning the external levers or control knobs, use only a soft cloth and soap. Never use cleaners containing abrasives or solvents as they may damage the chrome plating.

3.12 Periodicity Of In-Service Testing

The frequency of in-service testing depends upon the condition of the water passing through the Horne 15. In-service testing must be carried out more frequently in hard water areas than in soft water areas. As a general guide, in-service testing should be carried out at intervals somewhere between 6 and 12 months. In-service testing should be carried out at least every 12 months and, where the water is hard, the interval may be less than 6 months. Experience of local conditions and the in-service testing record will dictate the required frequency of in-service testing. In the absence of practical experience of this, a first check 6 – 8 weeks after commissioning should be performed. If no problems are detected (and mixed water temp is within 1°C of the commissioning temp) then checking again 12 – 15 weeks after commissioning to help build up a history. The results should be recorded on the attached sheet. Any requirement to reset the mixed water temperature should be noted. If no such adjustments are required, then the next in-service tests can be scheduled for 24 – 28 weeks after commissioning. If small adjustments (1 to 2 K) are required then check the strainers for cleanliness, make sure the isolating valves are fully open and verify the check valves are operating correctly (see Maintenance Section). The next in-service test should be conducted 18 - 21 weeks after commissioning. If larger adjustments are required (>2K), then service work is required, and the in-service tests should be repeated 18 – 21 weeks after commissioning. Note that the pressure and temperatures of the supplies must be identical to those during commissioning for the in-service tests to be meaningful.

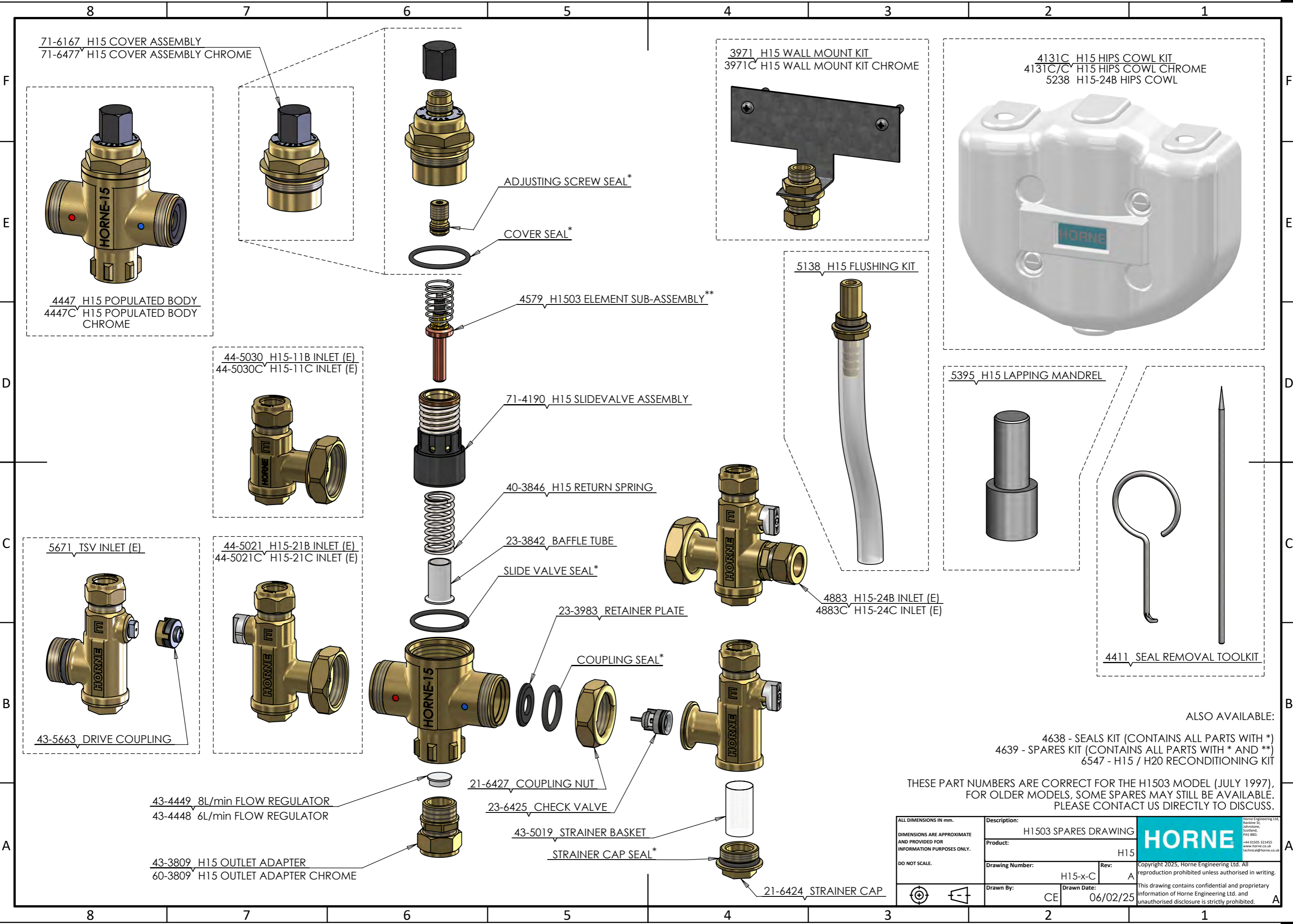

ALSO AVAILABLE:

- 4638 - SEALS KIT (CONTAINS ALL PARTS WITH *)
- 4639 - SPARES KIT (CONTAINS ALL PARTS WITH * AND **)
- 6547 - H15 / H2O RECONDITIONING KIT

THESE PART NUMBERS ARE CORRECT FOR THE H1503 MODEL (JULY 1997), FOR OLDER MODELS, SOME SPARES MAY STILL BE AVAILABLE. PLEASE CONTACT US DIRECTLY TO DISCUSS.

ALL DIMENSIONS IN mm. DIMENSIONS ARE APPROXIMATE AND PROVIDED FOR INFORMATION PURPOSES ONLY. DO NOT SCALE.	Description:		
	Product:		
	Drawing Number:	Rev:	
	Drawn By:	Drawn Date:	
		H1503 SPARES DRAWING	
		H15	
		H15-x-C	A
		CE	06/02/25

Copyright 2025, Horne Engineering Ltd. All reproduction prohibited unless authorised in writing. This drawing contains confidential and proprietary information of Horne Engineering Ltd. and unauthorised disclosure is strictly prohibited.

TO REMOVE FLOW REGULATOR

- 1> REMOVE THE 2 CAPHEAD SCREWS (USING 3MM HEX KEY)
- 2> PRISE SPRAYPLATE OUT WITH A BLADE OR SIMILAR
- 3> REMOVE THE RETAINING RING
- 4> REMOVE FLOW REGULATOR WITH ITS O-RING

STEPS <3> AND <4> CAN BE DONE BY TURNING ON THE WATER SUPPLY AND CATCHING THE PARTS IN A BUCKET

TO RE-FIT FLOW REGULATOR

- 1> INSERT FLOWREG INTO HOLE, FLANGED SIDE UP (FACING THE WATER SUPPLY)
- 2> PUSH O-RING INTO GAP AROUND FLOWREG
- 3> INSERT RETAINING RING
- 4> FIT THE LARGE O-RING ONTO THE SPRAYPLATE AND FIT THE SPRAYPLATE
- 5> RE-FIT THE CAPHEAD SCREWS

NOTE THAT THE SPRAY PLATE CAN BE FITTED IN 2 DIFFERENT ORIENTATIONS TO ALLOW GREATER OR LESSER 'THROW' OF THE WATER.

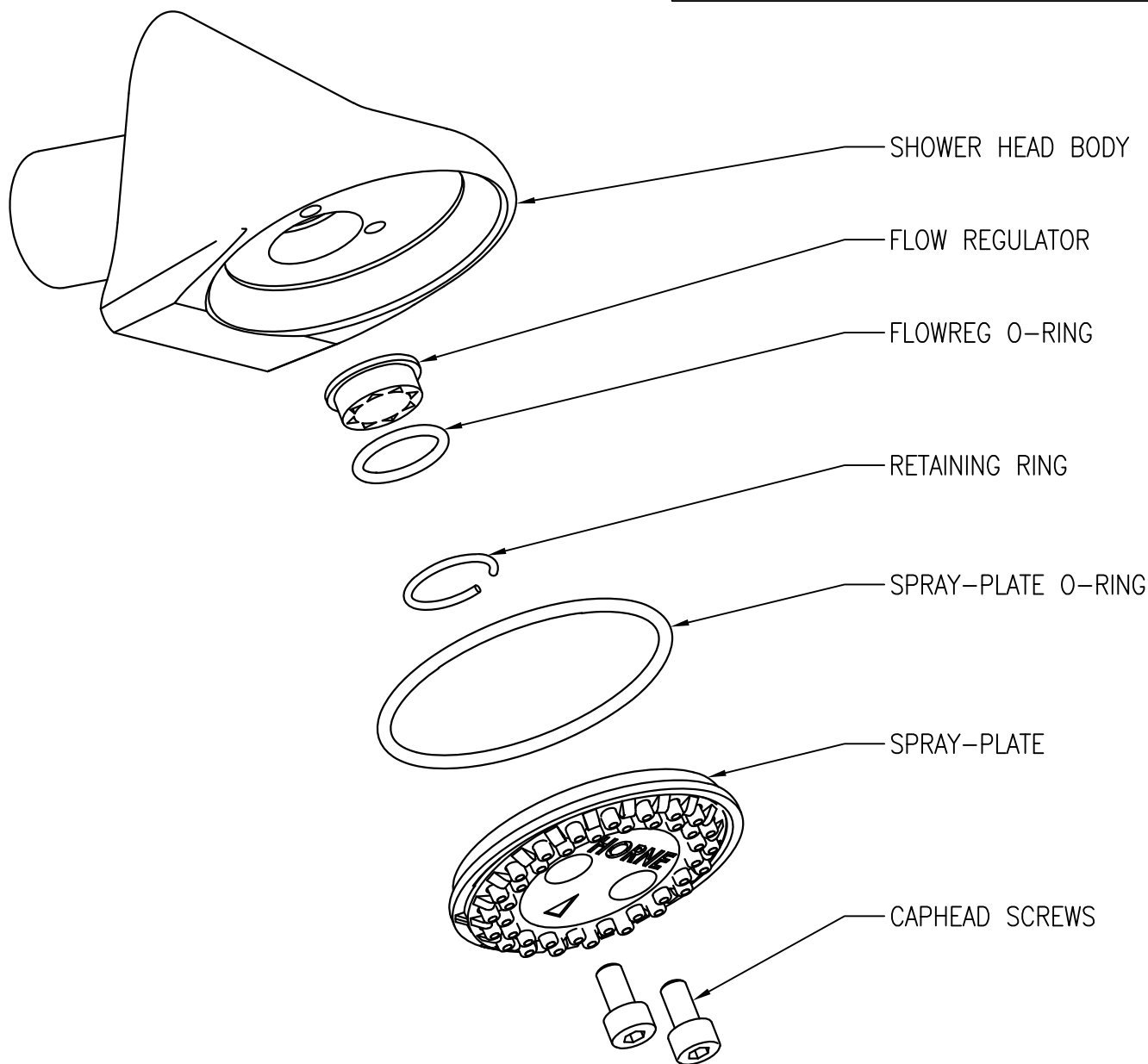

COPYRIGHT 2012, HORNE ENGINEERING LTD. ALL REPRODUCTION PROHIBITED UNLESS AUTHORISED IN WRITING

		MATERIAL : MATERIAL SPECIFICATION		HORNE ENGINEERING LTD. JOHNSTONE RENFREWSHIRE	
PART : REMOVAL / REPLACEMENT OF FLOW REGULATOR (VANDAL RESISTANT HEAD)	PRODUCT : HORNE SHOWER PANELS	SCALE	DO NOT SCALE	DR'G. No. 10393	
		DRAWN	MJ (18/11/2013)		
		CHECKED			
		ISSUE	2		

TO REMOVE FLOW-REGULATOR

1. UNSCREW SPRAY-HEAD FROM ANGLED TUBE
2. REMOVE FLOW REGULATOR AND WASHER
3. REPLACE WASHER
4. REFIT SPRAY-HEAD

TO FIT FLOW-REGULATOR

1. UNSCREW SPRAY-HEAD
2. REMOVE THICK WASHER FROM ASSEMBLY AND FIT FLOW-REGULATOR INSIDE IT (NOTE FLOW DIRECTION)
3. FIT FLOW-REGULATOR AND THICK WASHER TO SPOUT
4. SCREW THE SPRAY-HEAD TO THE SPOUT.

** THE EXACT NUMBER AND THICKNESS OF WASHERS WILL DEPEND ON WHICH SWIVEL-HEAD IS FITTED.

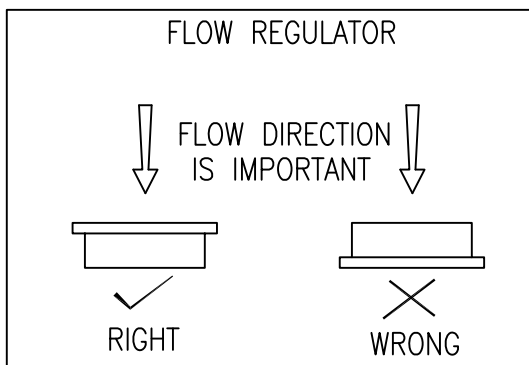
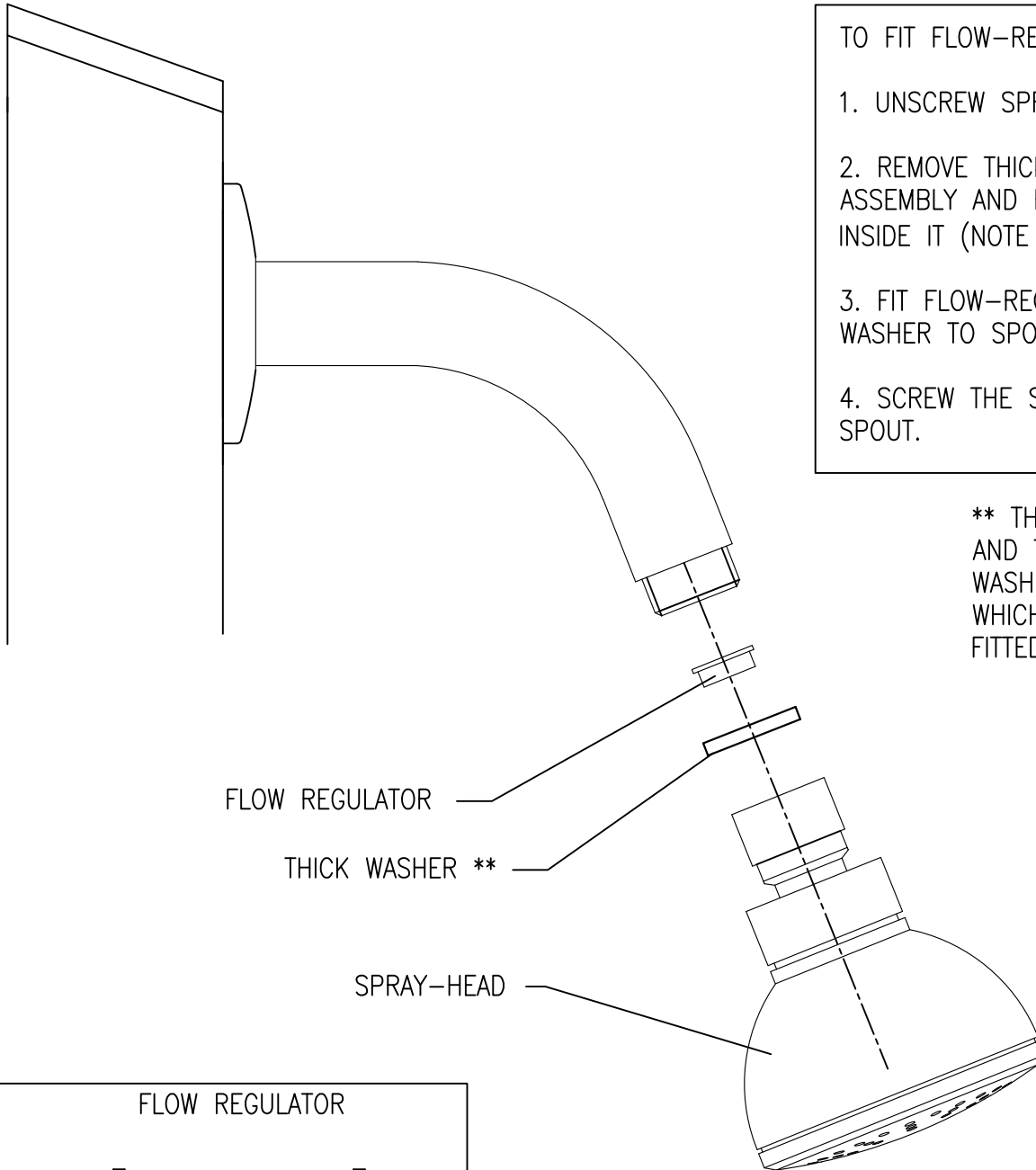

COPYRIGHT 2016, HORNE ENGINEERING LTD. ALL REPRODUCTION PROHIBITED UNLESS AUTHORISED IN WRITING

MATERIAL : N/A

HORNE ENGINEERING LTD.
JOHNSTONE
RENFREWSHIRE

PART :
REMOVAL/REPLACEMENT OF
FLOW REGULATOR

PRODUCT :
TSV1-106A/AB

SCALE	DO NOT SCALE
DRAWN	MJ (1/12/2020)
CHECKED	
ISSUE	5

DR'G. No. 9301B

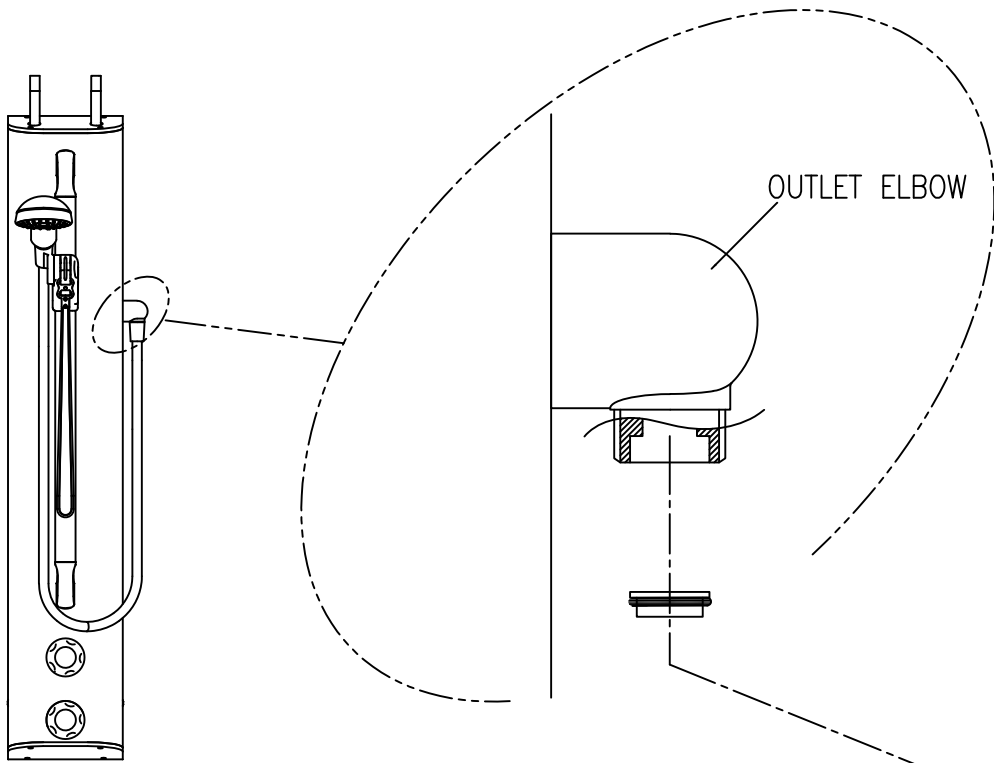

TO REMOVE/REPLACE THE FLOW REGULATOR

1. UNSCREW SHOWER HOSE FROM FIXED END
2. REMOVE, OR REPLACE REGULATOR (WITH O-RING ATTACHED, INTO THE OUTLET ELBOW, FLANGED SIDE FIRST IF REPLACING)
3. ENSURE THAT THE O-RING IS SEATED EVENLY IF REPLACING REGULATOR
4. RE-ATTACH SHOWER HOSE

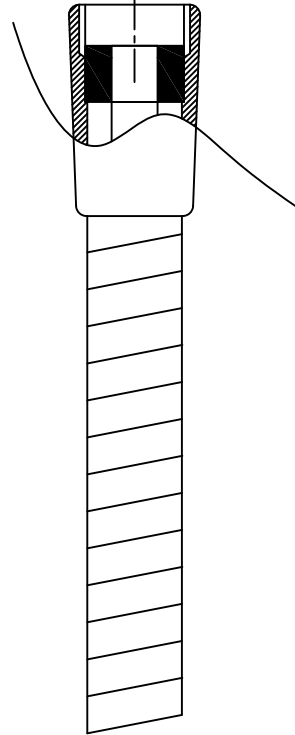

NOTE:
IF REPLACING,
FLOW DIRECTION
IS IMPORTANT

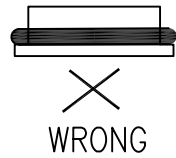
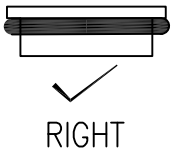

COPYRIGHT 2003, HORNE ENGINEERING LTD. ALL REPRODUCTION PROHIBITED UNLESS AUTHORISED IN WRITING

PART : FLOW REGULATOR REMOVAL/REPLACEMENT INSTRUCTIONS	PRODUCT : HORNE SHOWERS ALL HANDSET MODELS	MATERIAL : N/A		HORNE ENGINEERING LTD. JOHNSTONE RENFREWSHIRE DR'G. No. 9302B
		SCALE	DO NOT SCALE	
		DRAWN	GDP 7/12/05	
		CHECKED		
		ISSUE	3	

INSTRUCTIONS SPECIFIC TO SHOWER UNITS WITH RISER RAIL

TO ADJUST STIFFNESS OF ROTATING HANDSET HOLDER...



PRIZE DECAL COVER OFF HERE

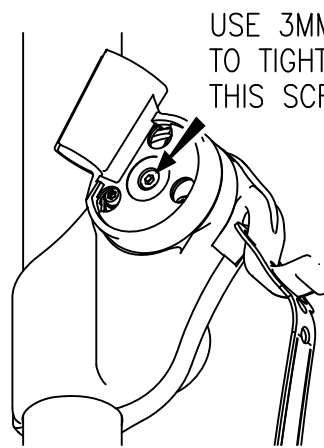

USE 3MM HEX KEY TO TIGHTEN OR LOOSEN THIS SCREW.

TO FIT THE DESCENDER (FOR ACCESSIBILITY)

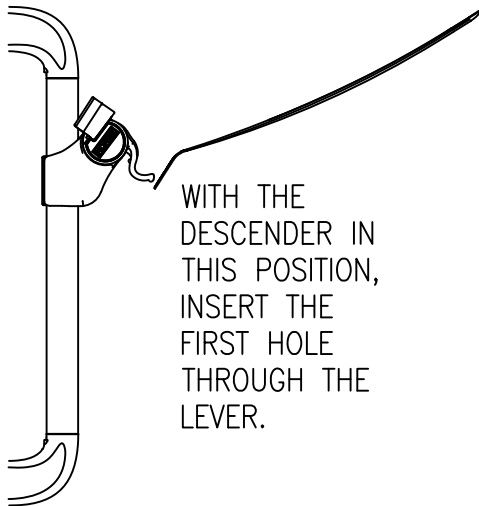

WITH THE DESCENDER IN THIS POSITION, INSERT THE FIRST HOLE THROUGH THE LEVER.

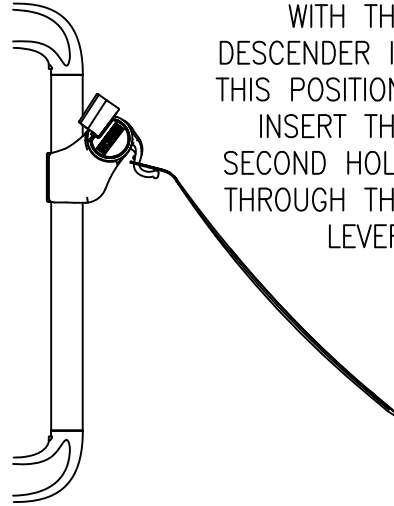

WITH THE DESCENDER IN THIS POSITION, INSERT THE SECOND HOLE THROUGH THE LEVER.

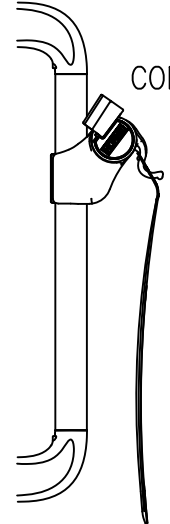

COMPLETE

TO REMOVE HANDSET HOLDER FROM THE RAIL, FIRST REMOVE DECAL COVER (SEE ABOVE), THEN USE TORX T15 DRIVER TO REMOVE THE 3 SCREWS AND THE ROTATING STIRRUP. REMOVE SCREW-COVER* AND SCREW FROM REVERSE OF HANDSET HOLDER, THEN INSERT A 50MM LONG X 3MM DIAMETER ROD (SCREWDRIVER) INTO THE HOLE AS SHOWN. HANDSET HOLDER WILL THEN SPLIT APART AND CAN BE REMOVED FROM THE RAIL.

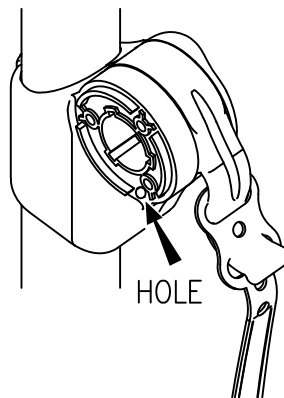

MAXIMUM LOADINGS FOR THE SHOWER RAIL (WHEN USED AS A GRAB-RAIL):-

LENGTH BETWEEN MOUNTING CENTRES	MAX. LOAD
0.8 M	120Kg
0.675 M	150Kg
0.39M	200Kg
0.29M	200Kg

* DRILL A SMALL HOLE THOUGH SCREW-COVER TO REMOVE IT.

HORNE ENGINEERING LTD.
JOHNSTONE
RENFREWSHIRE

DR'G. No. 11399

HORNE ENGINEERING LTD, RANKINE STREET, JOHNSTONE. PA5 8BD
 INSTRUCTION SHEET FOR ADJUSTING FLOW DURATION CUP
 TSV1 TIMED FLOW CONTROL UNITS BUILT AFTER APRIL 2010

1

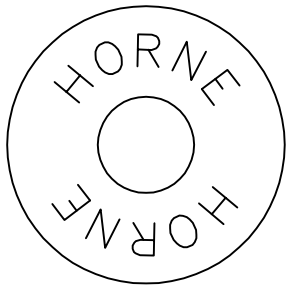

THIS INSTRUCTION SHEET IS ONLY APPLICABLE TO TSV1 PRODUCTS BUILT AFTER APRIL 2010. THESE CAN BE IDENTIFIED BY THE PUSHBUTTON BEING MARKED WITH "HORNE" AS SHOWN ABOVE. IF THE PUSHBUTTON DOES NOT HAVE THIS MARKING THEN THESE INSTRUCTIONS DO NOT APPLY.

2

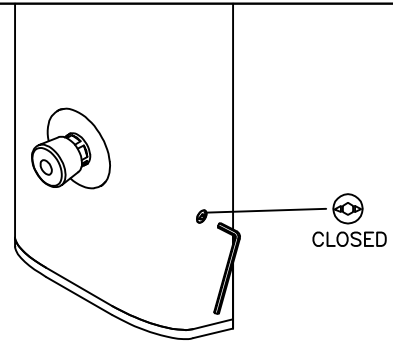

USE A HEX KEY TO ISOLATE THE HOT AND COLD WATER SUPPLIES AT THE LOW LEVEL SERVICING VALVES. THE INDICATOR ARROWS ON THE SERVICING VALVES WILL POINT TO THE FRONT AND THE BACK OF THE PANEL WHEN THE SUPPLIES ARE ISOLATED.

3

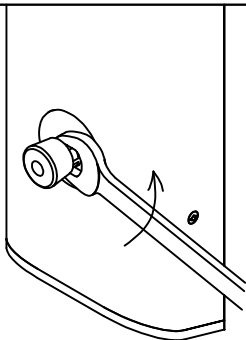

PRESS THE PUSHBUTTON TO RELEASE ANY TRAPPED PRESSURE. USING A SLIM JAW 24mm SPANNER ON THE HEX UNDER THE PUSHBUTTON, UNSCREW THE TIMED FLOW CONTROL CARTRIDGE.

4

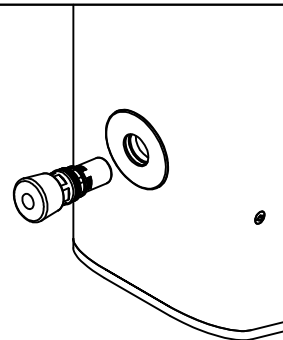

REMOVE THE TIMED FLOW CONTROL CARTRIDGE. BE CAREFUL NOT TO DROP THIS PRECISION PIECE OF EQUIPMENT. DO NOT PUT IT DOWN ANYWHERE WHERE IT COULD BECOME CONTAMINATED WITH DIRT OR DUST, NOR WHERE IT COULD BE STOOD ON.

5

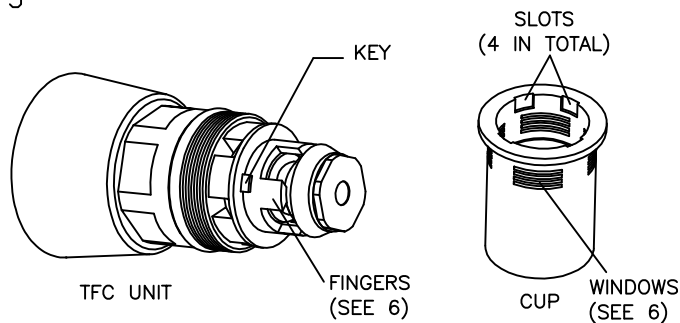

THE TFC UNIT HAS A KEY WHICH FITS INTO ONE OF 4 SLOTS IN THE CUP. THERE ARE THEREFORE 4 ORIENTATIONS OF THE TFC IN THE CUP. EACH OF THESE GENERATES A DIFFERENT FLOWRATE AND FLOW DURATION.

6

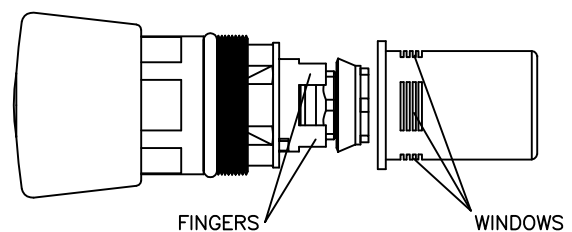

THE TFC UNIT HAS FINGERS WHICH BLANK OFF "WINDOWS" IN THE CUP WHEN ASSEMBLED. THE 4 ORIENTATIONS CORRESPOND TO 4 DIFFERENT DEGREES OF BLANKING. SECTION 7 SHOWS CLOSE-UP VIEWS OF THE WINDOWS AND EXPLAINS THE SIGNIFICANCE OF EACH ORIENTATION

7

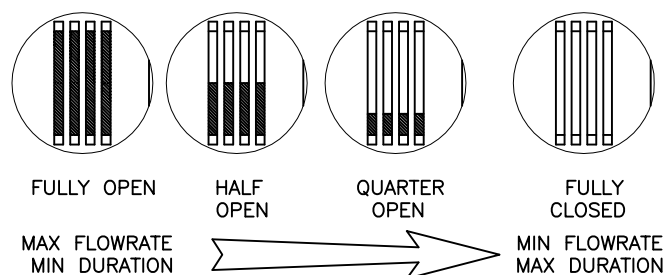

THE TFC UNIT HAS FINGERS WHICH COVER THE "WINDOWS" IN THE SIDE WALL OF THE CUP. SELECT THE MOST APPROPRIATE COMBINATION AS ABOVE, AND PUSH THE CUP ONTO THE CARTRIDGE.
 NOTE: THE PRODUCT IS SHIPPED IN THE FULLY OPEN CONDITION.

8

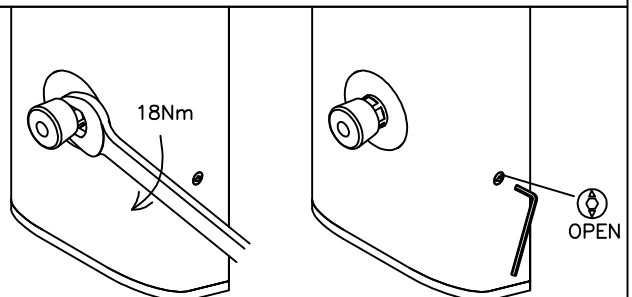

PUT THE CARTRIDGE BACK INTO THE SHOWER PANEL. TIGHTEN DOWN TO 18Nm. OPEN THE HOT AND COLD SUPPLIES AT THE SERVICING VALVES. THE INDICATOR ARROWS ON THE SERVICING VALVES WILL POINT UP AND DOWN WHEN THE SUPPLIES ARE OPEN. PUSH THE BUTTON TO PURGE THE AIR AND THEN VERIFY THE PERFORMANCE OF THE CARTRIDGE.

ADJUSTING FLOW DURATION THROUGH PISTON TRAVEL

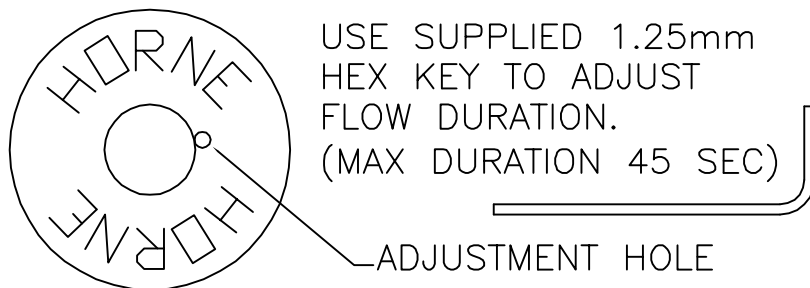

TURN CLOCKWISE TO REDUCE DURATION,
ANTI-CLOCKWISE TO INCREASE DURATION.
(ADJUSTS THE MAXIMUM PISTON STROKE).

CLEANING THE TIMED FLOW-CONTROL CARTRIDGE

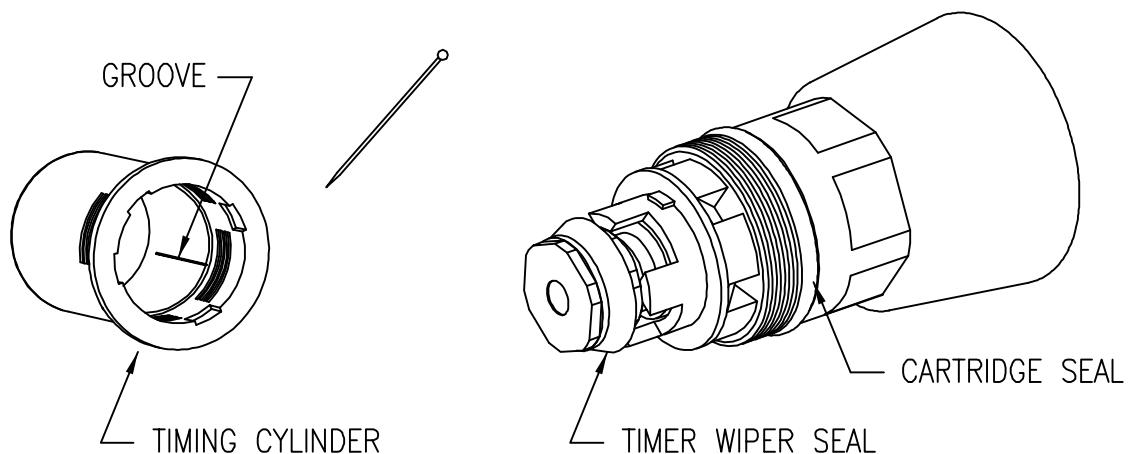

IF THE TFC CARTRIDGE BECOMES JAMMED (WON'T MOVE OUT TO CLOSED POSITION), REMOVE THE CARTRIDGE IN ACCORDANCE WITH STEPS 2-4, THEN PULL THE TIMING CYLINDER FROM THE CARTRIDGE ASSEMBLY. CLEAN OUT THE GROOVE INSIDE THE TIMING CYLINDER BY GENTLY RUNNING THE SHARP END OF A PIN UP AND DOWN THE GROOVE. A SMALL AMOUNT OF DEBRIS SHOULD BE DISLODGED BY THIS ACTION. THE TIMING CYLINDER MAY BE RINSED UNDER CLEAN RUNNING WATER - ABRASIVES SHOULD NOT BE USED.

ALL SEALS SHOULD BE FREE FROM DEBRIS AND DAMAGE. THEY MAY BE RINSED UNDER CLEAN RUNNING WATER. THE WIPER SEAL IS NOT USER REPLACEABLE - A NEW TFC SHOULD BE OBTAINED IF ANY DAMAGE IS APPARENT.

RE-ASSEMBLE AND INSTALL ACCORDING TO STEP 8.

COMMISSIONING, MAINTENANCE & IN-SERVICE TESTING RECORD

Establishment:					
Type of Valve: Horne TFC Shower with Horne 15 Thermostatic mixing valve		Date Installed:		Installed by:	
Location of Valve:					
Commissioning Details [Fill in ALL information during commissioning]					
Hot Water Supply :	HW Temp	°C	HW Pressure	Bar	Instrumentation: Temp:
Cold Water Supply:	CW Temp	°C	CW Pressure	Bar	Pressure:
Mixed Temp at max draw-off:	Mixed Temp: °C		Flowrate at max draw-off: l/min		
Mixed Temp at low draw-off:	Mixed Temp: °C		Flowrate at low draw-off: l/min		
Instrumentation Used:	Temp:		Press:		Flow:
Cold Water Isolation Test	Max Mixed Water Temp during CW Isolation test: °C		Mixed Water Temp on restoration of CW Supply: °C		
Note: MWT should return within 2 degrees of set temp, and be no greater than 43°C after this test.					
Comments:					

In-Service Testing Record		Establishment:		Location of Valve:	
Date:		Type of Valve : <i>Horne 15 (within TFC shower panel)</i>			
Hot Water Supply :	HW Temp	°C	HW Pressure	Bar	Instrument used (temp):
Cold Water Supply:	CW Temp	°C	CW Pressure	Bar	Instrument used (pressure):
Mixed Temp at max draw-off:	Mixed Temp:	°C	Flowrate at max draw-off:	l/min	
Mixed Temp at low draw-off:	Mixed Temp:	°C	Flowrate at low draw-off:	l/min	
Instrumentation Used:	Temp:		Press:	Flow:	
Cold Water Isolation Test	Max Mixed Water Temp during CW Isolation test: °C				Mixed Water Temp on restoration of CW Supply: °C
	MWT should return within 2 degrees of set temp, and be no greater than 43°C after this test.				
Comments:				Recommended Date of Next In-Service Test:	

In-Service Testing Record		Establishment:		Location of Valve:	
Date:		Type of Valve : <i>Horne 15 (within TFC shower panel)</i>			
Hot Water Supply :	HW Temp	°C	HW Pressure	Bar	Instrument used (temp):
Cold Water Supply:	CW Temp	°C	CW Pressure	Bar	Instrument used (pressure):
Mixed Temp at max draw-off:	Mixed Temp:	°C	Flowrate at max draw-off:	l/min	
Mixed Temp at low draw-off:	Mixed Temp:	°C	Flowrate at low draw-off:	l/min	
Instrumentation Used:	Temp:		Press:	Flow:	
Cold Water Isolation Test	Max Mixed Water Temp during CW Isolation test: °C				Mixed Water Temp on restoration of CW Supply: °C
	MWT should return within 2 degrees of set temp, and be no greater than 43°C after this test.				
Comments:				Recommended Date of Next In-Service Test:	

Pipe Cover Kit for Aluminium Shower Panels with In-Line Thermal Disinfection Unit (ILTDU) Fitted INSTALLATION INSTRUCTIONS

Installation requirements and specifications

Note that this Pipe Cover Kit is ONLY suitable for the Horne Range of **Aluminium** Shower Panels.

There are two different lengths of Pipe Cover Kit available for Aluminium Shower Panels – 465mm long and 940mm long. Please ensure that you have the appropriate length for your application.

Ensure that you have been supplied with the correct Pipe Cover Kit and that the Pipe Cover is long enough to fully cover the gap between the panel and the ceiling.

Fit the Aluminium Shower Panel to the wall in accordance with the Installation Instructions supplied.

Identify the components of the pipe cover kit by comparing the contents with the drawing shown on Page 4.

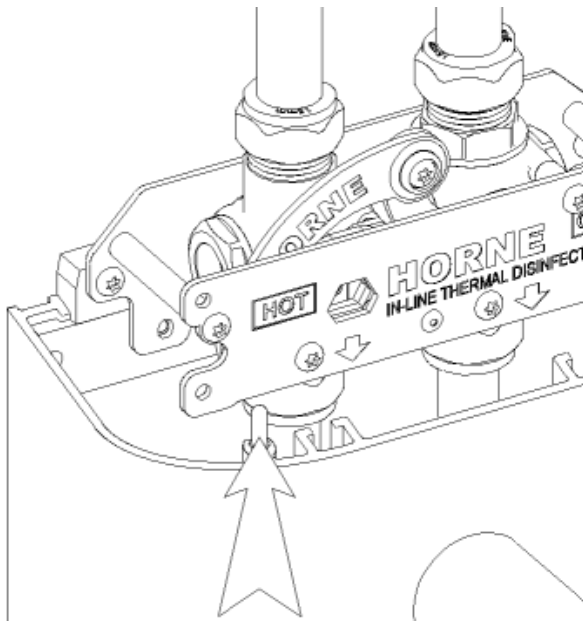

Fig. 1

Put the two Alignment Pins into the circular recesses in the Channel Section of the Shower Panel. See Fig. 1.

Place the silicone Interface Gasket onto the top of the Shower Panel, noting that it only fits one way, and that the rectangular guides engage with the rectangular recesses in the Channel Section of the Shower Panel. See Fig. 2.

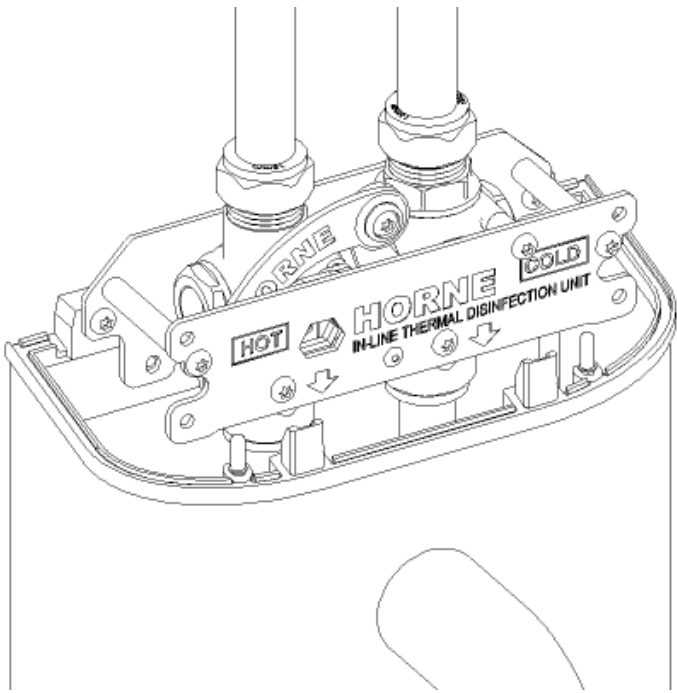

Fig. 2

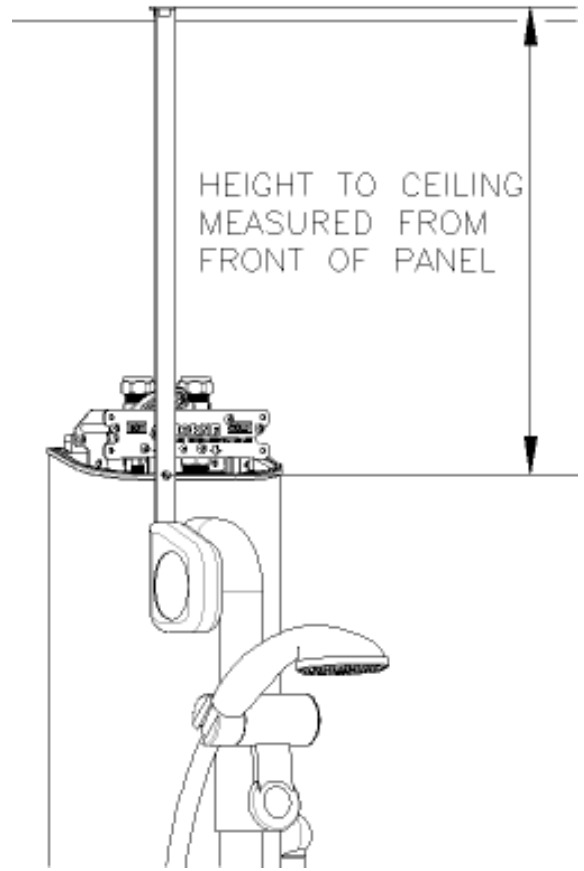

Fig. 3

Slide the Pipe Cover down into place, engaging with both the Alignment Pins and the Interface Gasket. If there are multiple cover sections, this should be repeated, ensuring the bottom section includes the key hole for ILTDU operation and leaving the section with the 90° end cut closest to the ceiling. If the Pipe Cover(s) is too long to do this, then measure the distance between the ceiling and the panel and cut the square **TOP** end of the Pipe Cover to make the Pipe Cover 15mm **SHORTER** than the measured distance, using a saw suitable for use with aluminium. See Fig. 3 and 4.

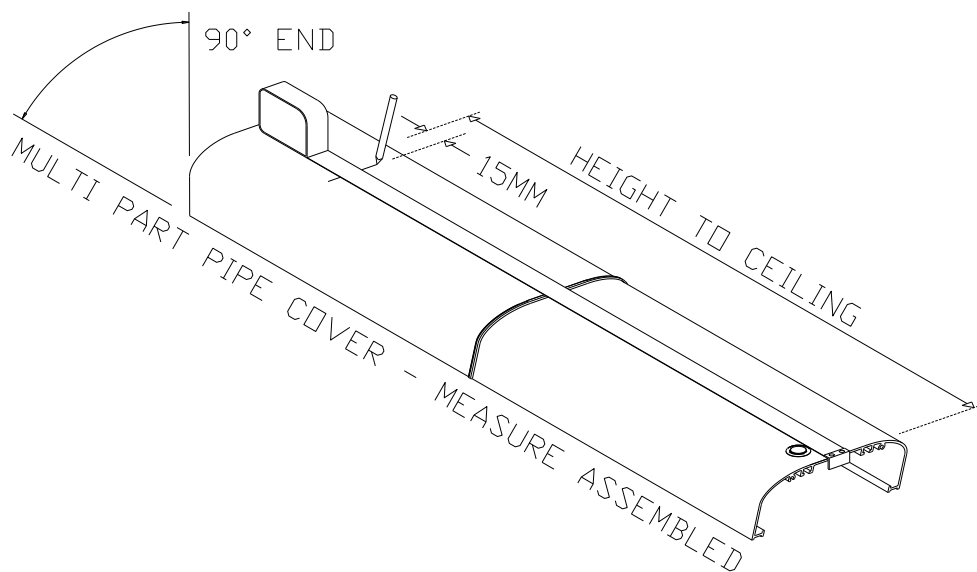

Fig. 4

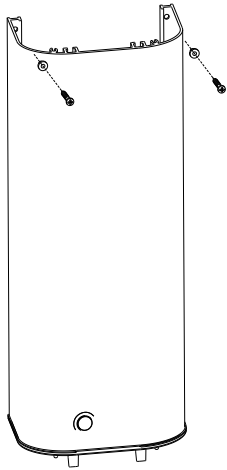

Fig 5.

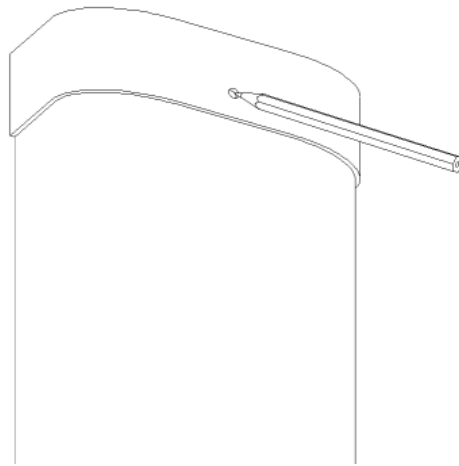

Fig 6.

For multi-section pipe covers, the intermediate lengths should be secured to the wall using the mounting holes available at the angled top cut.

Install the lowest section with gasket and alignment pins, atop the mounted shower panel. Mark off the mounting points and then secure the lower cover portion to the wall with supplied screws and bushes, using wall plugs where necessary. See Fig. 5

Slide the Pipe Cover (or top sections thereof) down into place and check for fit. The top of the Pipe Cover should be approx. 15mm from the ceiling when pressed firmly into place. Position the Saddle over the top of the Pipe Cover and against the ceiling with the hole in its lower position. Mark through the hole in the Saddle onto the Pipe Cover. See Fig. 6.

Remove the Saddle and drill the Pipe Cover with a 7 mm drill where marked. See Fig. 7.

Replace the Saddle and Pipe Cover and put in the screw to mark the wall. Ensure the mark made, **is with the screw perpendicular to the panel**. If appropriate, drill the wall to take the screw, or fit appropriate wall plugs. **N.B. Make sure that no debris enters the ILTDU during this if the pipe drops have not been installed.**

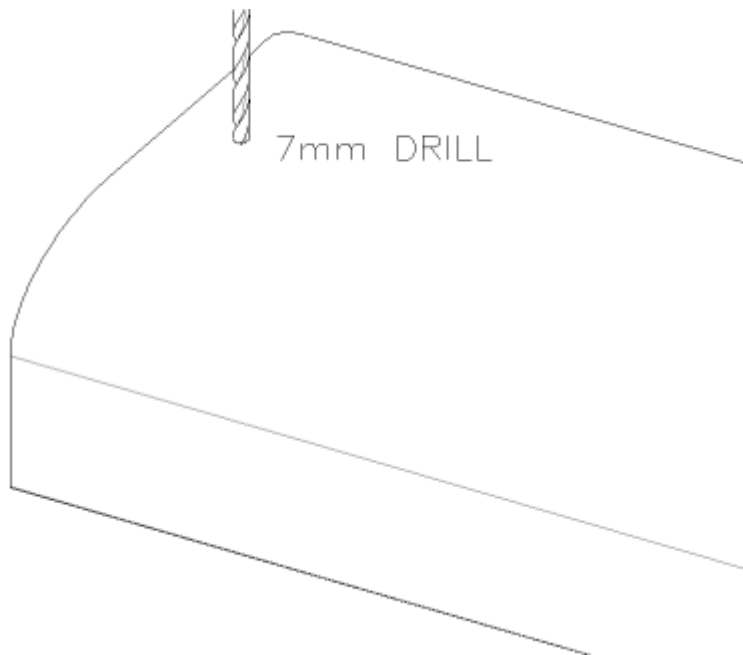
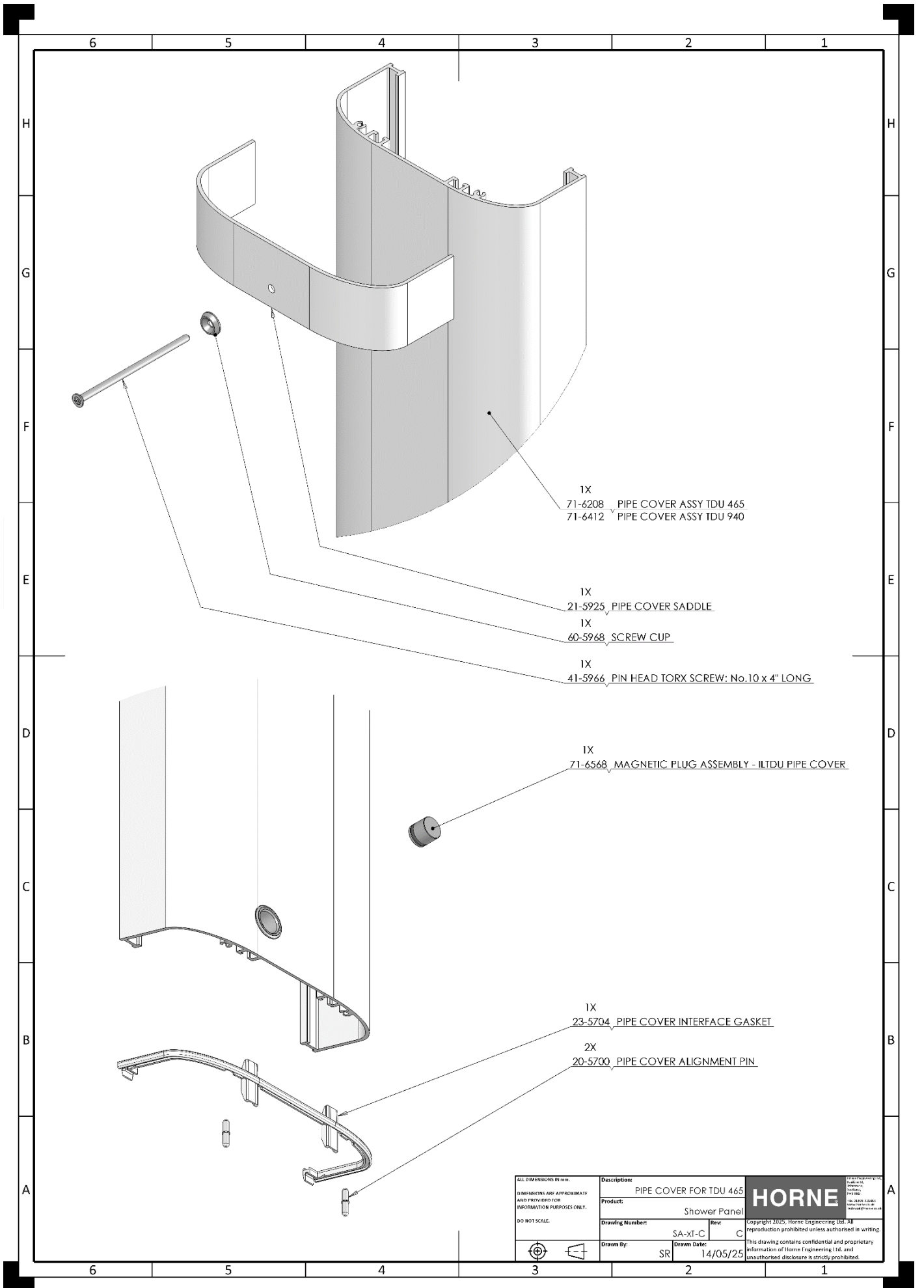

Fig. 7.

Finally, assemble the saddle to the cover by putting the Pin-Torx Security Screw through the Screw Cup, Saddle and Pipe Cover. **Do not over-tighten the Pin-Torx screw or the Saddle edges will splay out and give a poor appearance.** Silicone sealer can be used at the joint edges if required.

The drawing on Page 4 shows the exploded assembly view of the Pipe Cover and Saddle installation. *Note that pipe cover assemblies with multiple sections, will have multiples of some of the items listed.*



OPERATING INSTRUCTIONS ADDENDUM

In-Line Thermal Disinfection Unit (ILTDU) Integrated with Horne Thermostatic Shower Panels.

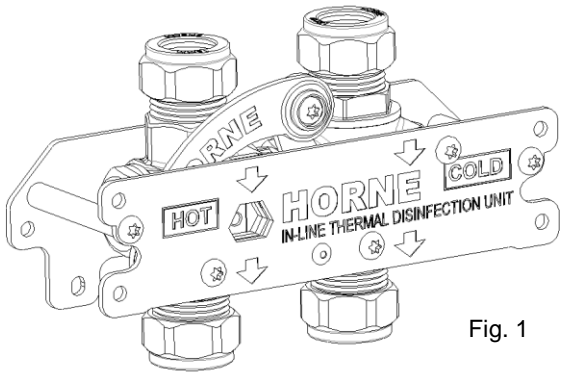

Fig. 1

Overview

The HORNE In-Line Thermal Disinfection Unit (ILTDU), shown in Fig.1, when supplied as an integrated component within a Horne shower panel, provides a simple and convenient way to pass hot water, at system hot water temperature through the entire product, in order to thermally disinfect all downstream pipework and fittings up to and including the shower outlet.

When integrated as part of a Horne shower panel, the ILTDU is mounted on top of the panel, and is concealed when the supplied ILTDU specific pipe cover is installed. Actuation with the operating key is facilitated by an access hole in the pipe cover, so there is no requirement to remove it for the disinfection operation. A safety blanking plug is supplied to cover the access hole (Part No. 71-6568); it is removed with the Magnet accessory (Part No. 43-6569) when thermal disinfection is to be undertaken.

- **LOCAL RISK ASSESSMENT SHOULD ALWAYS PREVAIL IN DICTATING THE PARAMETERS FOR DISINFECTION.** In absence of this, a hot water temperature of 60.0°C or greater, and duration of at least 10 minutes may be used as a starting point. Disinfection efficacy reduces significantly at temperatures below 60.0°C. Calibrated thermometers are a necessity.

How it works

The HORNE ILTDU directs system Hot & Cold Water to the corresponding Hot & Cold inlets of a mixing device, when in “passive” mode. However, when deliberately switched to “Disinfecting mode”, the ILTDU re-directs HOT water to the COLD inlet of the mixing device, via the interconnecting COLD pipework. This bypasses the temperature control function of thermostatic devices, allowing HOT water to flow from the outlet at elevated temperature. This disinfects all system components and pipework between the ILTDU and the water outlet.

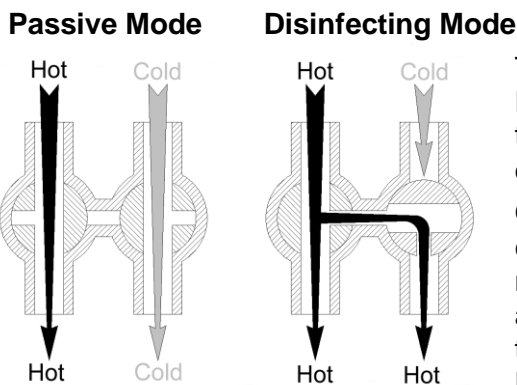

Fig. 2

The HORNE ILTDU has two operating modes – PASSIVE and DISINFECTING (Fig. 2). In PASSIVE mode, the ILTDU passes the hot and cold water supplies straight through to the mixing device and the mixing device operates normally.

Only the Horne ILTDU specific OPERATING KEY (Part No 6236) can be used to switch between PASSIVE and DISINFECTING modes. A single clockwise half turn of the OPERATING KEY activates DISINFECTING mode. This synchronously operates two 3-way ball valves to divert the hot water supply to both the HOT and COLD outlets of the HORNE ILTDU.

The outlet is run and this rapidly results in the pipework downstream of the HORNE ILTDU, the mixing device and the Outlet Fitting all being raised to system hot water temperature.

WARNING: Scalding water at system hot water temperature will discharge from the outlet fed by the mixing device during disinfection and so suitable safety precautions must be taken to reduce the risk of scalding, or damage to sanitary ware, etc.

The OPERATING KEY is specially shaped and interlocked such that it cannot be removed from the ILTDU while the ILTDU is in DISINFECTING mode. The OPERATING KEY has a large red warning triangle chained on to it. This serves as a local visual reminder on the ILTDU that it is being used in DISINFECTING mode

and that safety precautions should be taken. A replacement key should be sought if the warning triangle is missing.

After passing hot water through the mixing device for the desired period, the OPERATING KEY is turned back to its original position and the key is removed from the ILTDU. Removal of the OPERATING KEY from the ILTDU confirms that the ILTDU is in PASSIVE mode and that disinfection has ceased.

It should be noted that disinfection is a completely separate process from cleaning, and this ILTDU only disinfects components using system hot water. An elevated velocity flush should also be undertaken to help clean the treated system and get rid of any loosened biofilm.

Connect up the supplies, Leak-Test, and Commission the ILTDU

Ensure that the installation is free from leaks and then commission the ILTDU as follows:

- Check that the ILTDU is connected exactly as shown in Fig. 3. It is essential for correct operation that the supply and outlet connection indications are observed.
- *Before* inserting the OPERATING KEY, open the supplies and run the outlet until normal temperature at the outlet is reached. Measure and record this temperature.
- Insert the OPERATING KEY into the ACCESS SLOT on the ILTDU front plate through access hole in the pipe cover, removing the pipe cover keyhole safety plug with a magnet (Part No. 43-6569) where necessary.
- Turn the OPERATING KEY exactly a half turn clockwise, until you feel the mechanism reaching the end stop. The short leg of the OPERATING KEY should now be pointing upwards (towards the supply pipework).

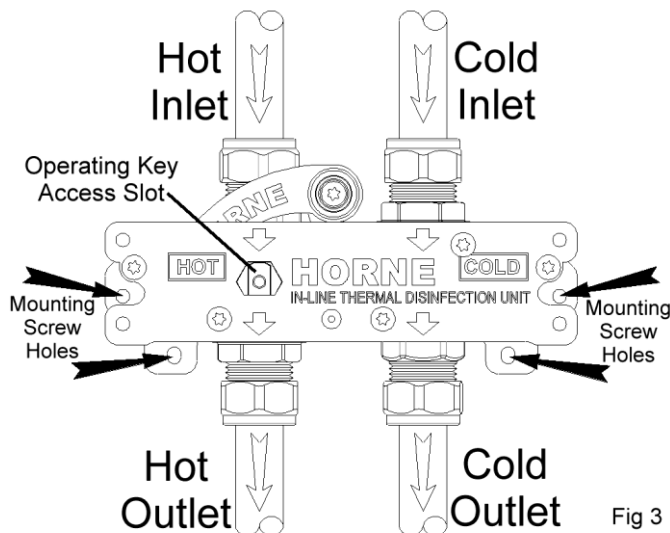

end stop. The short leg of the OPERATING KEY should now be pointing upwards (towards the supply pipework).

- The OPERATING KEY cannot be removed from the ILTDU in this position. This is intentional, to prevent the ILTDU from being accidentally left in the DISINFECTING MODE.

- Measure the water temperature at the outlet and ensure that it is at system hot water temperature. **Note that if the hot water system cannot achieve 60.0°C, it is unlikely that effective disinfection will be achievable within a reasonable timescale.**

- Turn the OPERATING KEY back half a turn anti-clockwise against the end stop, remove the key and replace the safety plug, if fitted. Ensure that the temperature at the outlet rapidly returns to the set temperature recorded prior to disinfection.
- Perform a cold water isolation test on the shower to ensure that it is still providing scald protection.
- ALWAYS remove the OPERATING KEY from the HORNE ILTDU when the device is in the PASSIVE MODE. Do NOT leave the OPERATING KEY in the device when in PASSIVE mode.

The HORNE ILTDU is now commissioned.

Using the HORNE ILTDU

Before the ILTDU is used, a local risk assessment should be undertaken to establish:

- Any bacterial load present and the most appropriate time/temperature regime to deal with it.
- The scalding risk and how to minimise it during disinfection.
- Any necessary precautions to protect sanitaryware from the hot water.
- The most appropriate frequency for a disinfection routine to be scheduled.

The use of the HORNE ILTDU as integrated with a HORNE Shower Panel will now be described.

- Ensure that the Hot Water Temperature available is consistent with that recommended by the local risk assessment. Note that a **minimum of 60.0°C** is normally required for disinfection.
- Ensure that no unauthorised or vulnerable people are able to access the shower while the disinfection process is underway.
- Perform a cold water isolation test on the shower panel being disinfected. If the cold water isolation test is satisfactory then proceed with the disinfection procedure. If the TMV does not pass the test, then address that, before proceeding, by following normal maintenance procedures for the TMV. These are described in the Instructions for the Shower Panel.
- Fully turn on the shower, and then insert the OPERATING KEY into the HORNE ILTDU, removing the pipe cover keyhole safety plug with a magnet (Part No. 43-6569) where necessary. Turn the OPERATING KEY one half turn clockwise, against the end stop. The OPERATING KEY will remain in the HORNE ILTDU during this time – it cannot be removed.
- The red warning triangle attached to the OPERATING KEY serves as a highly visible reminder that the ILTDU is in DISINFECTING MODE. For this reason, do not use the OPERATING KEY without the warning triangle attached.
- **Note: Do NOT remove the Shower Hose or the Shower Handset during thermal disinfection; it is vital that each of these parts is fully thermally disinfected.**
- **Thermal disinfection should be applied to all wetted components to be effective. If any kind of filter is fitted to the outlet, advice should be sought from the filter manufacturer as to whether their product can withstand appropriate disinfection temperatures.**
- Measure the temperature of the water coming out of the shower head. This should rise to system hot water temperature. When it reaches the minimum temperature recommended by the local risk assessment, start timing, and permit the water to run for the required duration. Measure the temperature during this time to ensure that the temperature is maintained at the required high level. If the temperature does not reach the required level, or is not maintained at the required level, stop the process and address the water temperature. Satisfactory disinfection cannot be assured otherwise.
- After the water has run for the required time at the required temperature, turn the OPERATING KEY one half turn anti-clockwise back to its original position, again against the end stop; remove the key and replace the safety plug, if fitted. Always remove the OPERATING KEY whenever the ILTDU is returned to the PASSIVE mode. Do not leave the OPERATING KEY in the ILTDU when it is in PASSIVE mode.
- Let the shower run for a few minutes and monitor the temperature to make sure the water temperature returns to a safe and comfortable limit.
- Perform a cold water isolation test on the TMV and ensure that it closes off the hot water supply, and is thus still capable of preventing scalding, then check that the correct mixed water temperature is re-established. If the TMV does not pass the cold water isolation test, perform regular maintenance operations on the TMV, and do not allow use of the shower panel until the TMV satisfactorily prevents hot water flow on isolation of the cold inlet.
- Record the parameters of the disinfection process on a record sheet (see page 8 of this document, or download a customisable sheet from www.horne.co.uk)
- Note that disinfecting is a separate process from cleaning. This process will disinfect the TMV and pipework, but will not, in itself, clean the system. It is advisable to perform an elevated velocity flushing procedure, using an appropriate Horne Flushing Kit for the Shower, to encourage the reduction of biofilm and debris if present. The use of a Horne Flushing Kit permits full-bore flushing and bypasses flow regulators within the panel in order to achieve the maximum water velocity possible.

Maintenance

The HORNE ILTDU has no user serviceable parts, and does not require any ongoing maintenance, other than occasional cleaning and lubrication of the metal link mechanism with SILICONE oil, to prevent friction in operation. If the ILTDU fails to work properly, it should be replaced. No attempt should be made to disassemble the ILTDU.

If the OPERATING KEY is lost, do not attempt to operate the ILTDU without it. It will not operate satisfactorily, the ILTDU could be damaged, and it is dangerous. Replacement Keys (Part No 6236) can be ordered from Horne Engineering Ltd (contact details on front cover).

The Horne ILTDU is patented. EU Patent No. EP2948716

RECORD SHEET for HORNE In-Line Thermal Disinfection Unit (ILTDU)
(Integral to Horne TSV1 Shower Panel)

In-Service Usage Record
Establishment: Location of ILTDU: Shower Outlet protected:

Date:	Facilities Operator	Elevated velocity flush carried out too?	Yes/No
Temperature measured at outlet during thermal disinfection:°C	Duration of thermal Disinfection: mins	cfu count before use: (if appropriate)	cfu count after use: (if appropriate)

Date:	Facilities Operator:	Elevated velocity flush carried out too?	Yes/No
Temperature measured at outlet during thermal disinfection:°C	Duration of thermal Disinfection: mins	cfu count before use: (if appropriate)	cfu count after use: (if appropriate)

Date:	Facilities Operator:	Elevated velocity flush carried out too?	Yes/No
Temperature measured at outlet during thermal disinfection:°C	Duration of thermal Disinfection: mins	cfu count before use: (if appropriate)	cfu count after use: (if appropriate)

Date:	Facilities Operator :	Elevated velocity flush carried out too?	Yes/No
Temperature measured at outlet during thermal disinfection:°C	Duration of thermal Disinfection: mins	cfu count before use: (if appropriate)	cfu count after use: (if appropriate)

Date:	Facilities Operator :	Elevated velocity flush carried out too?	Yes/No
Temperature measured at outlet during thermal disinfection:°C	Duration of thermal Disinfection: mins	cfu count before use: (if appropriate)	cfu count after use: (if appropriate)

Date:	Facilities Operator :	Elevated velocity flush carried out too?	Yes/No
Temperature measured at outlet during thermal disinfection:°C	Duration of thermal Disinfection: mins	cfu count before use: (if appropriate)	cfu count after use: (if appropriate)



HORNE 15 THERMOSTATIC MIXING VALVE – TYPE H-1503 INSTALLATION, COMMISSIONING AND MAINTENANCE INSTRUCTIONS

0.1 Approval

The Horne 15 Type H1503 Thermostatic Mixing Valve has been independently tested by an ISO 17025 Approved Test House and approved for the following designations and applications, to all the requirements of “Department of Health (DoH) HTM 04-01: Supplement – Performance specification D 08: thermostatic mixing valves (healthcare premises)”.

APPLICATION	DESIGNATION	HOT & COLD WATER PRESSURES	WATER TEMPERATURES
BIDET	LP-B HP-B	0.2 to 1 Bar 1 to 5 Bar	HOT: 55°C - 65°C COLD: 5°C - 20°C
SHOWER	LP-S HP-S	0.2 to 1 Bar 1 to 5 Bar	
WASHBASIN	LP-W HP-W	0.2 to 1 Bar 1 to 5 Bar	

The HORNE 15 TMV Type H-1503 is therefore classified as a Type 3 Thermostatic Mixing Valve according to HTM 04-01 Part A, and Health and Safety Executive HSIS6, 2012, document: Managing the risks from hot water and surfaces in health and social care. It also complies with Regulation 4 of the Water Supply (Water Fittings) Regulations 1999 and Water Bylaws (Scotland) 2014.

0.2 Backflow Prevention

The hot and cold swivel inlets to the Horne-15 valve each include a single in-line Reg 4 approved DN15 Check Valve.

0.3 Supply Pressure Requirements

The minimum water pressure required is a dynamic head of 2m (3 psi, 0.2 bar). Note that the dynamic head is the pressure measured with the water running.

Where the Horne 15 is fed by supplies with differing pressures, a pressure-reducing valve (PRV) may be required on the inlet with the higher pressure to prevent pulsing of the flow. Although this has minimal effect on thermostatic control, the flow pulsing is often considered undesirable.

Note that output flowrate is always determined by the lower of the two inlet pressures.

0.4 Operating Conditions Required for TMV Type 3 Compliant Installations

	High Pressure	Low Pressure
Maximum Static Pressure	10Bar	10Bar
Flow Pressure, Hot & Cold	1 to 5Bar	0.2 to 1Bar
Hot Water Supply Temperature	55 – 65°C	55 – 65°C
Cold Water Supply Temperature	5 – 20°C	5 – 20°C
Minimum Temperature Differential (Hot/Mixed, Mixed/Cold)	5°C	5°C

NB: OUTSIDE OF THESE CONDITIONS, VALVES CANNOT BE EXPECTED TO OPERATE AS TYPE 3 VALVES.

0.5 Temperature Adjustment Range

The range of temperature adjustment is 35 - 46°C for the standard product. Extended adjustment range can be had with the optional low or high range elements. Note the correct temperatures for NHS applications in section 2.3.3.

SECTION 1: INSTALLATION

The HORNE 15 TMV can be fitted in any attitude with the mixed water outlet pointing upwards, downwards, horizontally or any angle between these planes. It must be installed so that it is accessible for commissioning and maintenance. If the particular model of Horne 15 being installed does not include isolation valves, there must be some means to isolate the hot and cold supplies individually, for in-service testing purposes. See section 4.1.

1.1 Installation Procedure

- 1.1.1 Check that the HORNE 15 TMV is approved for the intended application – see section 0.1.
- 1.1.2 Install the HORNE 15 TMV as close as possible to the outlet to comply with HTM 04-01. The dead leg from the HORNE 15 TMV to the outlet should not exceed 2 metres. 500mm of table Y copper pipe between the TMV and the outlet is beneficial for smoothing start transients, especially with sensor taps.
- 1.1.3 Check that the supply pressures are within the ranges given in section 0.4. Additionally, note the comment regarding pressure reducing valves, in section 0.3.
- 1.1.4 Check that the supply temperatures are within the ranges stated in section 0.4.
- 1.1.5 Connect the hot water supply to the port on the valve with the RED dot, and the cold-water supply to the port with the BLUE dot.

IT IS VERY IMPORTANT THAT NO WATER IS ALLOWED TO PASS THROUGH THE VALVE UNTIL THE FLUSHING PROCEDURE DETAILED IN SECTION 1.3 IS CARRIED OUT.

1.2 Flow Regulator Fitting

- 1.2.1 To avoid unnecessary wastage of hot water, the optional flow regulator supplied with the HORNE 15 TMV can be fitted at the mixed water outlet. The small disc flow-regulator supplied, white in colour, will control flow to 8 L/min $\pm 10\%$ at pressure-drops of between 2 and 5 Bar.
- 1.2.2 The flow regulator (see drawing H15-x-C below) fits between the outlet pipe and the compression fitting. It is not recommended to fit flow regulators at the inlet connections.

1.3 Flushing of Pipework (see diagram overleaf)

Flushing is required by Water Fittings Regulations 1999, schedule 2 G13.1, the Water Bylaws 2014 (Scotland) and BSEN 806 and is also essential for the function of the TMV. The most common cause for complaint regarding the performance of any Thermostatic Mixing Valve is traced to dirt or debris in the TMV or check valves.

The hot and cold-water pipework should be thoroughly flushed using the Flushing Kit shown in the diagram overleaf. The Flushing Kit comprises a screwed adaptor to fit the strainer body and a plastic pipe to enable water to be flushed to drain. Only one or two kits are required on each site. The kit, part number 5138, must be ordered separately.

DO NOT OPEN THE HOT WATER TAP BEFORE FLUSHING THE HOT AND COLD-WATER PIPEWORK.

The flushing procedure is as follows. During this procedure, keep the hot and cold-water taps closed.

- 1.3.1 Close the hot and cold-water Isolating Valves.
- 1.3.2 Unscrew the End Cap (21) and remove the Strainer Basket (19) from the strainer at the hot inlet.
- 1.3.3 Screw the Flushing Kit into the Strainer Body (18).
- 1.3.4 Place the outlet of the flushing pipe where it can drain freely. If draining into a wash basin or bath, make sure that the drain plug is NOT in place and that water passing through the flushing pipe is free to drain.
- 1.3.5 Open the hot water Isolating Valve and allow any air in the pipework to escape until water begins to flow to drain. Allow water to flow to drain AT FULL BORE until any pipework which has been worked on has been cleared
- 1.3.6 Close hot water Isolating Valve.
- 1.3.7 Remove the Flushing Kit and replace the strainer basket and end cap.
- 1.3.8 Repeat 1.3.2 to 1.3.7 at the cold-water inlet with the cold-water Isolating Valve.
- 1.3.9 Re-open both Isolating Valves.
- 1.3.10 The flushing procedure has now been completed.

DO NOT FLUSH THE PIPEWORK BY REMOVING THE STRAINER BASKETS AND OPENING THE TAPS.

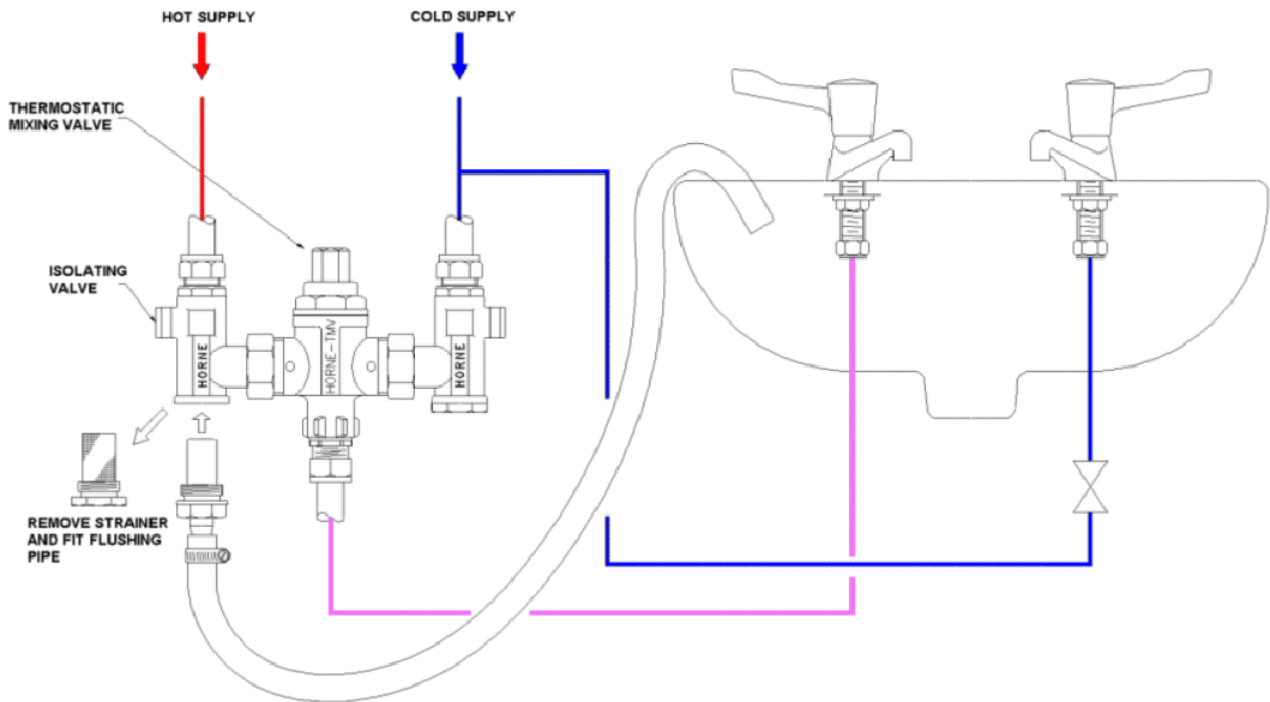

NOTE THAT IF THE SYSTEM IS NOT TO BE COMMISSIONED IMMEDIATELY AND/OR THERE IS ANY DANGER OF FREEZING THEN THE VALVE MUST BE DRAINED TO AVOID DAMAGE. OPEN THE STRAINER CAPS TO DRAIN THE VALVE.

1.4 Test for Leaks in the Pipework

Open the supplies at the upstream or integral isolating servicing valves and check for any leaks at the supply pipe joints. Do not open the downstream tap. Make good any leaks found. The valve is now ready for commissioning.

SECTION 2: COMMISSIONING

NB: THE HORNE 15 CANNOT BE COMMISSIONED UNTIL HOT AND COLD WATER ARE AVAILABLE

Commissioning the valve involves flushing the water supply; setting the temperature; and finally performing a cold-water isolation test to confirm the safe operation of the valve as fitted. Flushing is included in the Installation Section to ensure it is done as soon as possible after installation but should be considered vital to the commissioning process. Commissioning the valve is essential to establish a reference point for future in-service tests, and to ensure the valve works correctly under site conditions.

2.1 Flushing of Pipework

2.1.1 Unless you are absolutely certain that this has been done, flush the pipework per section 1.3.

2.2 Pre-Checks

Ensure that the NHS designation of the valve matches the intended application, and that the requirements of section 0.4 above have been met. Ensure that the water supplies to the valve are open.

2.3 Setting the Temperature

2.3.1 Open the hot water tap and allow water to run through the HORNE 15 TMV.

2.3.2 Check that hot and cold-water supplies stabilise at or near to their designated temperatures and pressures.

2.3.3 Measure the temperature at the hot water tap. This is the temperature of the mixed water. For healthcare / D08 applications set the Mixed Water Temperature as in the table over:

Application	Mixed Water Temp.	Notes
Bidet	38°C	A TMV with multiple designations should be reset on site to suit the appropriate designation. For healthcare/Type 3 applications, the mixed water temperature should never exceed 46°C. For washbasins, washing under running water is assumed.
Shower	41°C	
Washbasin	41°C	

- 2.3.4 During commissioning, the valve **MUST** be adjusted **DOWN** to temperature. This is to ensure that the hot water system is capable of supplying water, *at the working flowrate*, in excess of the required outlet temperature by a margin of at least 5°C. Note that not all instantaneous water heaters will be capable of this. Start by setting the valve to 5°C higher than required by adjustment of the 4mm hex screw on top of the valve (see 3.1.2 below); measure and confirm the elevated temperature, and then reduce the temperature to the required level. If the valve cannot be set to 5°C higher than required, then the outlet temperature is being controlled by the inlet conditions, and not by the valve, therefore the commissioning is not complete, and **VULNERABLE USERS SHOULD NOT BE ALLOWED TO OPERATE THE TAPS**.
- 2.3.5 Using a 4mm hex key, turn the adjusting screw clockwise to reduce the mixed water temperature or anti-clockwise to increase it. Adjust not more than half-a-turn at a time, allowing the temperature to stabilise between adjustments. To confirm that the temperature has been properly set, isolate the hot supply briefly before opening again to check the set-temperature.
- 2.3.6 Record the commissioning information, including equipment used, on the attached commissioning sheet to permit the in-service performance of the valve to be assessed in the future.

2.4 Cold Isolation Test

- 2.4.1 Finally, check the thermal shut-off facility of the TMV by performing a Cold Isolation Test (sometimes colloquially called a “fail-safe” test) as follows. With the water running at a normal flowrate, isolate the cold-water supply to the valve. If there is any flow after 5 seconds, this must amount to no more than 120ml in 60 seconds of collecting. If there is more than this amount, find possible corrective actions in the “Maintenance” section below. If the Cold Isolation Test is satisfactory, restore the supply and note the final stabilised temperature in the commissioning log. This should be within 2°C of the original temperature. Generally, the mixed water temperature should not rise by more than 2.9°C during this cold-water isolation test. Record the result of this on the attached commissioning sheet. If the Cold Isolation Test is satisfactory, restore the supply and note the final stabilised temperature in the commissioning log.
- 2.4.2 Failure of the Cold Isolation Test at commissioning is usually due to dirt particles that have migrated into the valve from the pipework. This is why flushing is essential.

NOTE THAT INCOMING HOT-WATER TEMPERATURE MUST BE MAINTAINED IN THE RANGE DESCRIBED IN SECTION 0.4 FOR THIS TEST TO BE VALID. REFER TO THE MAINTENANCE SECTION OF THIS BOOKLET OR PHONE THE FACTORY FOR ADVICE, IF NECESSARY.

2.5 Test the Check-Valves

- 2.5.1 Although check-valve failures are rare, verifying their operation at commissioning time in a large installation can give peace of mind later. Refer to section 3.8.

SECTION 3: MAINTENANCE

Maintenance of all Thermostatic Mixing Valves is essential to ensure they continue to operate to specification after installation and continue to offer scald protection. Record all maintenance carried out on the attached Commissioning & Maintenance Record sheet at the back of these instructions.

3.1 In Service Testing

- 3.1.1 Periodic testing should be carried out to check whether any deterioration has occurred in the performance of the valve. Note that instrumentation to the same specification should be used each time when measurements are taken to ensure consistency of results.
- 3.1.2 Also record any requirement to adjust the Mixed Water Temperature on the in-service testing record.

NOTE: A THERMOSTATIC MIXING VALVE IN NEED OF MAINTENANCE CAN BE UNDETECTABLE IN NORMAL USE AND ONLY BECOME APPARENT WHEN DISRUPTION OCCURS IN THE HOT OR COLD-WATER SUPPLY TEMPERATURES OR PRESSURES. IN SERVICE TESTING SHOULD BE CARRIED OUT AT A FREQUENCY DETERMINED BY LOCAL RISK ASSESSMENT TO DETECT ANY SUCH DETERIORATION.

3.2 Routine Servicing Schedule

- 3.2.1 Replace the "O" rings **every three years** (Maintenance kit with spare "O" rings available). It is especially important to replace the slide-valve seal, located in a groove in the valve body. Horne tool 4411 is helpful for this job. See the Horne website "maintenance" section for further instruction and videos.
- 3.2.2 Replace the Thermostat Element **every 6 years**, or more often if problems are experienced or in installations where the water is aggressive.
- 3.2.3 Replace the slide-valve assembly if it becomes damaged. This may happen due to scale or grit in the water.

3.3 Strainer Baskets

- 3.3.1 Initially check the strainer baskets for debris every three months and clean if required. This period can perhaps be increased later if it is established that the water is generally clean and free of debris.

3.4 Cold Isolation Test – Corrective Actions for Failure

- 3.4.1 Regularly perform a Cold Isolation Test and check the maximum temperature setting as described in the section 3.2 above. If the valve fails this test then consider the following:
 - ◇ Perform an Isolation Test as section 3.2 but shut the hot instead of the cold. If this results in a similar rate of flow as when shutting the cold, then consider that there may be a problem with the slide-valve seal. See section 4.2.1.
 - ◇ Opening and cleaning the valve can cure problems caused by dirt in the pipework which has migrated into the valve, but note that if water cleanliness is poor, or flushing is not carried out, then dirt can damage the slide-valve knife-edge faces. Damage will necessitate replacement of the slide-valve.
 - ◇ Cleaning/dressing of the hot valve seat may be necessary if the valve is old and/or scaled. This can be done with Horne tool 5395, and some toothpaste or fine grinding paste.
 - ◇ Failure of the Cold Isolation Test can be caused by hot water in the cold supply: test the check-valves.
 - ◇ In the water supply is 'hard', then de-scaling of the valve may be necessary. See section 4.6.

3.5 Notes on Dismantling

- 3.5.1 If removing the valve from pipework, do not grip the valve body in a vice, as this could distort the body and jam the internal parts.
- 3.5.2 All internal components of the Horne 15 can be removed as shown in drawing H15-x-C below.
- 3.5.3 Treat all parts with care when removing from the valve body. Note especially that the slide-valve is a precision component and can easily be damaged.
- 3.5.4 Do not forget the slide-valve seal, partially hidden in a groove in the valve body. Horne tool 4411 can be used to remove it. Be careful not to scratch the groove sides whilst removing the seal. This and all other plastic/rubber parts must be removed before de-scaling.

3.6 Notes on Descaling

- 3.6.1 If the valve body requires de-scaling, first remove all o-Ring seals and internal parts, then use a proprietary de-scaling fluid. Do not put the thermostat element or any plastic/rubber parts in de-scaling fluid.
- 3.6.2 Inspect the condition of the "Hot Valve Face" and "Cold Valve Face". If the valve faces show signs of deterioration, they can be resurfaced as follows.
 - ◇ Re-surface the Hot Valve Face using a mandrel (Horne part no. 5395) and a water-soluble scouring paste (toothpaste works quite well).
 - ◇ Use P800 Grade wet abrasive paper on a flat surface to smooth the "Cold Valve Face".
- 3.6.3 Prior to re-assembly of the valve, ensure it is clean and all debris is removed.

3.7 Notes on Re-assembly

- 3.7.1 Make sure all components are clean before re-assembly. It is recommended to fit new o-rings.
- 3.7.2 Ensure the slide-valve seal is fitted in the body and is in good condition.
- 3.7.3 Smear silicon oil (not grease) on all "O" rings prior to installation. Also lightly smear the outside diameter of the slide-valve with silicon oil before fitting.
- 3.7.4 Ensure the slide-valve seal is fitted in the body, and is in good condition.
- 3.7.5 Fit the components into the valve body using drawing H15-x-C (below) as a guide.
- 3.7.6 For optimal thermostatic performance, orient the visible tail end of the return spring towards the hot inlet side before inserting the slidevalve. Then turn the thermostatic adjustment to the cold position (until the

thread almost releases) *before* screwing on the cover. This will prevent components turning as the cover is screwed on.

3.7.7 After any dismantling of the valve, perform a Cold Isolation Test per Section 2.4 to verify correct re-assembly.

3.8 Testing of Check-Valves

3.8.1 The Check Valves prevent crossflow between hot and cold-water supplies under unequal pressure conditions and are designed for long life with no maintenance. Their function can be tested as follows:

3.8.2 Start with the outlet to the valve closed and both hot and cold isolating valves open.

3.8.3 To test the Check Valve on the hot side, shut off the hot supply and ensure the cold supply is open. Be prepared for leakage of trapped water from the pipe and remove the strainer basket on the hot side. Any continuing leakage evident from the strainer body is likely to be coming through the hot supply Check Valve (N.B. Ensure the hot isolating valve shuts off tightly, or it may cause leakage here). Testing of the cold-side check valve is a mirror of this process.

3.8.4 If either Check Valve is passing, then the inlet elbow (complete with Check Valve and strainer basket) should be replaced. It is not possible to satisfactorily remove the Check Valve itself from the inlet elbow and this should not be attempted.

3.9 Periodicity of In-Service Testing

3.9.1 The frequency of in-service testing depends upon the condition of the water passing through the TMV. In-service testing must be carried out more frequently in hard water areas than in soft water areas. Generally, in-service testing should be carried out at intervals somewhere between 6 and 12 months. In-service testing should be carried out at least every 12 months and, where the water is hard, the interval may be less than 6 months. Experience of local conditions and the in-service testing record will dictate the required frequency of in-service testing. In the absence of practical experience of this, a first check 6 – 8 weeks after commissioning should be performed. If no problems are detected (and mixed water temp is within 1°C of the commissioning temp) then checking again 12 – 15 weeks after commissioning to help build up a history. The results should be recorded on the attached sheet. Any requirement to reset the mixed water temperature should be noted. If no such adjustments are required, then the next in-service tests can be scheduled for 24 – 28 weeks after commissioning. If small adjustments (1 to 2 K) are required then check the strainers for cleanliness, make sure the isolating valves are fully open and verify the check valves are operating correctly (see Maintenance Section). The next in-service test should be conducted 18 - 21 weeks after commissioning. If larger adjustments are required (>2K), then service work is required, and the in-service tests should be repeated 18 – 21 weeks after commissioning. Note that the pressure and temperatures of the supplies must be identical to those during commissioning for the in-service tests to be meaningful.

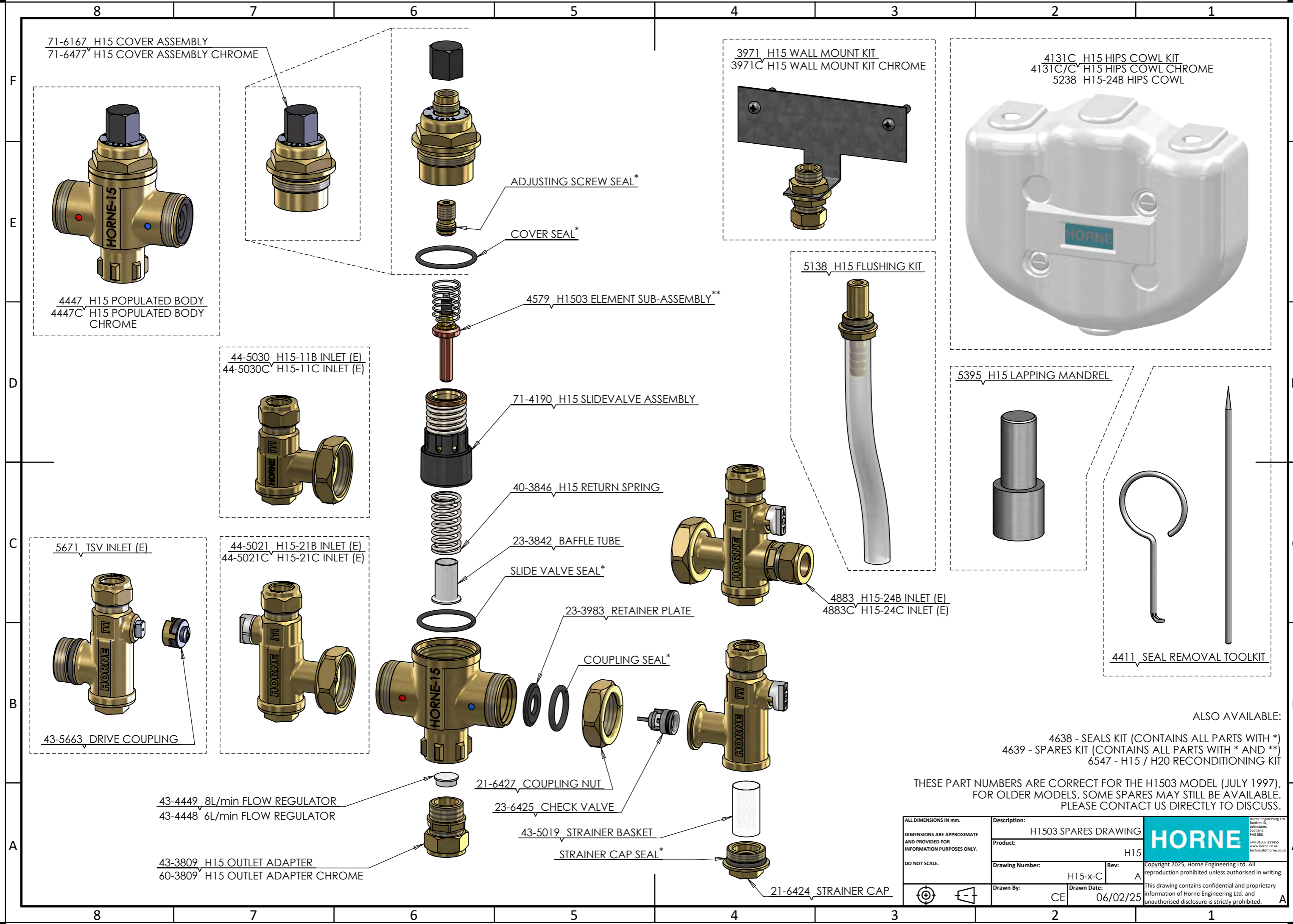

ALSO AVAILABLE:

4638 - SEALS KIT (CONTAINS ALL PARTS WITH *)
4639 - SPARES KIT (CONTAINS ALL PARTS WITH * AND **)
6547 - H15 / H2O RECONDITIONING KIT

THESE PART NUMBERS ARE CORRECT FOR THE H1503 MODEL (JULY 1997),
FOR OLDER MODELS, SOME SPARES MAY STILL BE AVAILABLE.
PLEASE CONTACT US DIRECTLY TO DISCUSS.

ALL DIMENSIONS IN mm. DIMENSIONS ARE APPROXIMATE AND PROVIDED FOR INFORMATION PURPOSES ONLY. DO NOT SCALE.	Description:		
	H1503 SPARES DRAWING		
	Product:		
	H15		
Drawing Number:		Rev:	Copyright 2025, Horne Engineering Ltd. All reproduction prohibited unless authorised in writing. This drawing contains confidential and proprietary information of Horne Engineering Ltd. and unauthorised disclosure is strictly prohibited.
H15-x-C		A	
Drawn By:	CE	Drawn Date:	
		06/02/25	

Horne Engineering Ltd
 FAULT FINDING CHART

SYMPTOM	POSSIBLE CAUSE	ACTION	REFER TO SECTION
Mixed water temperature too high	Temperature setting too high. Temperature has been set when the hot water temperature is too low	Re-adjust temperature setting	2.3
	Hot water has migrated into cold water supply	Inspect Check Valve at cold inlet If the check valve leaks replace the strainer body and check valve sub-assembly	3.8 Drg. H15-x-C
	Thermostat Element has failed. This can be checked by carrying out a hot or cold-water failure test.	Replace element (8)	3.2.2
Mixed water temperature too low	Temperature Setting too low	Re-adjust temperature setting	2.3
	Hot water supply temperature has fallen	Check hot water supply system	0.4
	Cold water has migrated into hot supply	Inspect Check Valve at hot inlet If the check valve leaks replace the strainer body and check valve sub-assembly.	3.8 Drg H15-x-C
	Cold valve face requires cleaning	Remove valve Cover (5) and service valve face	3.6.2
Mixed water flow rate too low.	Partly blocked strainers	Clean strainers	3.3
	Unusually high pressure-drop in supply pipework	Check all valves are full open. Check Pressurisation unit Check mains supply	
	Extra Demand added to system	Check pipe sizing	
Mixed water temp does not respond to adjusting screw	Slide-Valve (9) is seized	Valve requires de-scaling	3.6
	Hot and cold inlets reversed	Remove HORNE 15 TMV from pipes and reverse connections. Connect inlet with red dot to hot pipe	
Mixed water temp changes and is not steady	Slide-Valve (9) is seized	Valve requires De-Scaling	3.6
	Thermostat element has failed (This can be checked by carrying out a hot or cold-water failure test)	Replace element (8)	3.2.2
Water at outlet runs full hot or full cold	Hot and cold inlets are reversed	Hot inlet is marked with Red dot Cold inlet is marked with Blue dot	
Valve continues to pass cold-water when hot supply is isolated	Cold valve face requires cleaning	Remove valve cover (5) and service cold valve face	3.6.2
	Fouling at hot valve seat	Clean hot valve face	3.6.2
Valve continues to pass hot water when cold supply is isolated	Slide-Valve seal is damaged	Replace Slide-Valve Seal (13)	3.2.1
	Element has failed	Replace Element (8)	3.2.2

Horne Engineering Ltd
 COMMISSIONING, MAINTENANCE & IN-SERVICE TESTING RECORD

Establishment:				
Type of Valve: HORNE 15 Thermostatic Mixing Valve		Date Installed:		Installed by:
Location of Valve:				
Commissioning Details Note: Fill in ALL information during commissioning.				
Hot Water Supply :	HW Temp	°C	HW Pressure	Bar
Cold Water Supply:	CW Temp	°C	CW Pressure	Bar
Mixed Temp at max draw-off:		Mixed Temp: °C	Flowrate at max draw-off: l/min	
Mixed Temp at low draw-off:		Mixed Temp: °C	Flowrate at low draw-off: l/min	
Instrumentation Used:		Temp:	Press:	Flow:
Cold Water Isolation Test		Max Mixed Water Temp during CW Isolation test: °C Mixed Water Temp on restoration of CW Supply: °C Note: MWT should return within 2 degrees of set temp, and be no greater than temp shown below* for this test.		
Comments:				
In-Service Testing Record				
Date:				
Hot Water Supply :	HW Temp	°C	HW Pressure	Bar
Cold Water Supply:	CW Temp	°C	CW Pressure	Bar
Mixed Temp at max draw-off:		Mixed Temp: °C	Flowrate at max draw-off: l/min	
Mixed Temp at low draw-off:		Mixed Temp: °C	Flowrate at low draw-off: l/min	
Instrumentation Used:		Temp:	Press:	Flow:
Cold Water Isolation Test		Max Mixed Water Temp during CW Isolation test: °C Mixed Water Temp on restoration of CW Supply: °C Note: MWT should return within 2 degrees of set temp, and be no greater than temp shown below* for this test.		
Comments:				
Recommended Date of Next In-Service Test:				

*Max stabilised Mixed Water Temperatures: Bath (44°C fill) = 46°C, Bath (46°C fill) = 48°C, Washbasin = 43°C, Shower = 43°C

Horne Engineering Ltd
IN-SERVICE TESTING RECORD

(Note: Photocopy this page)

In-Service Testing Record		Establishment:		Location of Valve:	
Date:		Type of Valve : HORNE 15 Thermostatic Mixing Valve			
Hot Water Supply :	HW Temp	°C	HW Pressure	Bar	Instrumentation: Temp: Pressure:
Cold Water Supply:	CW Temp	°C	CW Pressure	Bar	
Mixed Temp at max draw-off:	Mixed Temp:	C	Flowrate at max draw-off:	l/min	
Mixed Temp at low draw-off:	Mixed Temp:	C	Flowrate at low draw-off:	l/min	
Instrumentation Used:	Temp:		Press:	Flow:	
Cold Water Isolation Test	Max Mixed Water Temp during CW Isolation test: °C				Mixed Water Temp on restoration of CW Supply: C
Note: MWT should return within 2 degrees of set temp, and be no greater than temp shown below* for this test.					
Comments:					
Recommended Date of Next In-Service Test:					

In-Service Testing Record		Establishment:		Location of Valve:	
Date:		Type of Valve : HORNE 15 Thermostatic Mixing Valve			
Hot Water Supply:	HW Temp	°C	HW Pressure	Bar	Instrumentation: Temp: Pressure:
Cold Water Supply:	CW Temp	°C	CW Pressure	Bar	
Mixed Temp at max draw-off:	Mixed Temp:	°C	Flowrate at max draw-off:	l/min	
Mixed Temp at low draw-off:	Mixed Temp:	°C	Flowrate at low draw-off:	l/min	
Instrumentation Used:	Temp:		Press:	Flow:	
Cold Water Isolation Test	Max Mixed Water Temp during CW Isolation test: °C				Mixed Water Temp on restoration of CW Supply: °C
Note: MWT should return within 2 degrees of set temp, and be no greater than temp shown below* for this test.					
Comments:					
Recommended Date of Next In-Service Test:					

*Max stabilised Mixed Water Temperatures: Bath (44°C fill) = 46°C, Bath (46°C fill) = 48°C, Washbasin = 43°C, Shower = 43°C