

HORNE®

Horne Engineering Ltd
PO Box 7, Rankine Street
Johnstone, Scotland, PA5 8BD
t: +44 (0)1505 321455
f: + 44 (0)1505 336287
e: technical@horne.co.uk
w: horne.co.uk

Optitherm Spares & Accessories Drawing No. 10321 Rev 13

Service Kits

Part Number	Description
71-5489	Lever Maintenance Kit
6670	O-Ring Kit (incl. strainer baskets [9] & outlet fitting [14]). Current (TBT-3) design.
5969	O-Ring Kit (incl. strainer baskets) – Legacy (TBT-2) design.
71-5472	Thermostatic Cartridge
71-5471	Thermostatic Cartridge Cover
43-6635	6L/min Outlet fitting – 24mm diam. Current (TBT-3) design.
23-6531	6L/min Outlet Fitting (Junior). Legacy (TBT-2) design.

Valve Components

Drawing Ref.	Part Number	Description
1	60-5404	Main Bottom Cover
2	42-5402	Body Seal O-Ring
3	71-5471	Thermostatic Cover Sub Assy
4	71-5472	Thermostatic Cartridge
5	20-5435	Tap Securing Screw
6	42-5429	Securing Screw O-Ring
7	71-5473	Cold Inlet Cartridge Assy
8	71-5474	Hot Inlet Cartridge Assy
9	43-5442	Strainer Mesh basket
10	42-2482-B	Rear Body Seal O-Ring
11	44-6638	Ceramic Disc Cold Side
12	60-5412	Actuator Endcap Blue
13	60-6604	Double Lever Right Cold Side
14	43-6635	6 L/min outlet fitting with Face Seal. Current (TBT-3) design.
14*	23-6531	Flow regulator Outlet Fitting & Seal. Legacy (TBT-2) design.
15*	71-6554	Anti-Dribble Collar. Legacy (TBT-2) design.
14 & 15*	71-6557	TBT Outlet Fitting Assy. Legacy (TBT-2) design.
16		Body not available as spare
17	71-5469	Interconnect Sub Assembly
18	71-5475-S	Spigot
19	60-5422-C	Bezel
20	71-5678	Inlet Compression Adaptor. Legacy (TBT-2) design.
21	5433	Extension Piece Short (200DL version)

Drawing Ref.	Part Number	Description
21	5434	Extension Piece Long (230DL version)
22	41-5432	M5 x 20 S/S Cap Screws
23	42-5461	Spigot Sealing Washer
24	44-6637	Ceramic Disc Hot Side
25	23-5408	Actuator Sleeve
26	42-5409	Actuator Sleeve O-Ring
27	20-5420	Spline Adaptor
28	23-5410	Torque Control Member
29	42-3452	Lever Interface O-Ring
30	60-6603	Double Lever Left Hot side
31	42-5416	Hub Cushioning O-Ring 2 per Side
32	41-5419	Lever Retaining Washer
33	41-5414	Lever Retaining Screw (M4x12)
34	60-5411	Actuator Endcap Red
35	43-5462	Pex Hose M10 (Obsolete)
36	43-5680	10mm Ferrule (2 Required)
37	43-5681	10mm Compression Nut

Conversion Kits

Part Number	Description
71-5652	Convert 170 to 200 Length Kit (30mm spacer)
71-5653	Convert 170 to 230 Length Kit (60mm spacer)
70-5905	Pair of dual levers
43-6635	Outlet fitting flow regulator/conditioner. Current (TBT-3) design.
71-6557	Anti-dribble outlet upgrade. Legacy (TBT-2) design.
TBT-ODL	Dual lever tap (without spigot or extension)

Tools and Accessories

Part Number	Description
5491	Full Tool Kit
5684	Flushing boot with jubilee clip
5492	(in-situ) Flushing Kit
44-5457	Strap wrench
44-6200	Stainless Steel 12mm HEX KEY
44-5654	4mm hex key
23-5459	Multi-tool
20-5458	Thermostatic Cartridge removal tool
44-6667	Outlet universal cache key – fits current & legacy outlets
23-6553	Outlet cache key – Junior. Legacy (TBT-2) design.
44-6076	Outlet cache key – <i>original</i> larger size. Legacy (TBT-2) design.

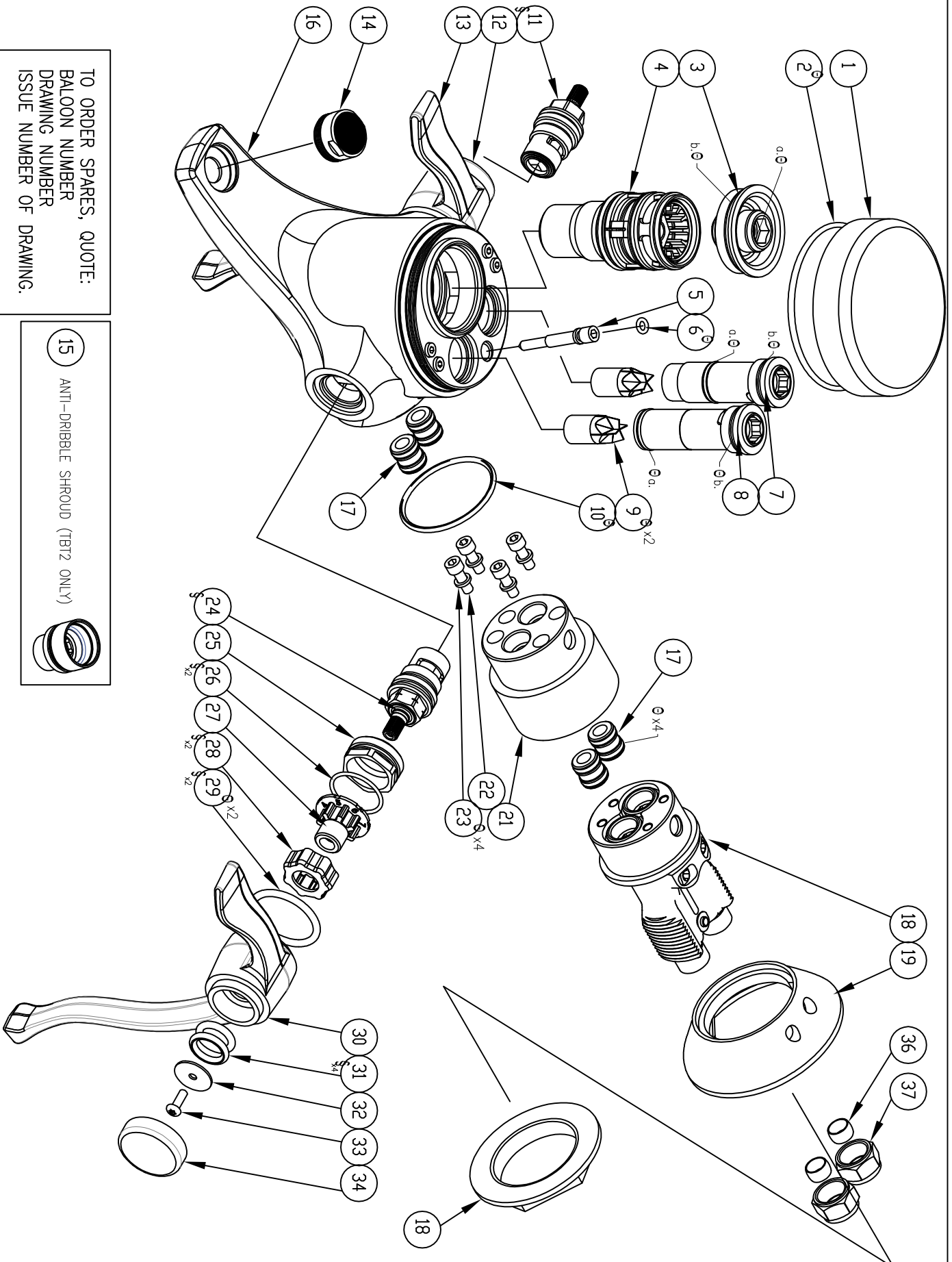

TO ORDER SPARES, QUOTE:
 BALOON NUMBER
 DRAWING NUMBER
 ISSUE NUMBER OF DRAWING.

15 ANTI-DRIBBLE SHROUD (TBT2 ONLY)

20 9×2

35 PEX HOSE
 OLD TBT2 VERSIONS ONLY

TBT-2 [SHEET 2]

TBT-3 [SHEET 3]

PARTS SHOWN ON SHEET 1 - TBT-2 BODY (PRE-2022)

ALTERNATIVE PARTS NOT SHOWN ON SHEET 1

BALLOON	PART NO.	DESCRIPTION	COMMENTS
	60-5404	MAIN BOTTOM COVER	-
1.	42-5402	BODY SEAL O-RING	-
2.	71-5471	THERMOSTATIC COVER SUB-ASSY	NOW SUPPLIED SEPERATE FROM (4)
3.	71-5472	THERMOSTATIC CARTRIDGE	NOW SUPPLIED WITHOUT COVER (3)
4.	71-5472	THERMOSTATIC CARTRIDGE	NOW SUPPLIED WITHOUT COVER (3)
5.	20-5435	TAP SECURING SCREW	-
6.	42-5429	SECURING SCREW O-RING	ALSO FOR BALL VALVE ACTUATOR
7.	71-5473	COLD INLET CARTRIDGE ASSY	-
8.	71-5474	HOT INLET CARTRIDGE ASSY	-
9.	43-5442	STRAINER MESH	-
10.	42-2482-B	REAR BODY SEAL O-RING	-
11.	44-6638	60° CERAMIC DISC: COLD SIDE	'RIGHT-TURN-CLOSE': NO MARKING
12.	60-5412	ACTUATOR ENDCAP BLUE	-
13.	60-5412-C	DOUBLE LEVER RIGHT	OBSOLETE (2023) - USE TBT3 LEVER
14.	23-6531	FLOWREG OUTLET FITTING & SEAL	NOW 21.5MM VERSION (6 L/MIN)
15.	71-6554	ANTI-DRIBBLE SHROUD	INCL. SEAL. STD FIT FROM AUG 2018*
16.	----	BODY: NOT AVAILABLE AS SPARE	-
17.	71-5469	INTERCONNECT SUB-ASSEMBLY	170 NEEDS 2, 200 & 230 NEED 4
18.	71-5475-S	SPIGOT WITHOUT EXTENSION (170)	INCLUDES BIG NUT, NOT BEZEL
19.	60-5422-C	BEZEL	-
20.	71-5678	INLET COMPRESSION ADAPTOR	LEGACY PART ONLY.
21.	5433/5434	EXTENSION PIECE	5433 (SHORT:200), 5434 (LONG:230)
22.	41-5432	M5 x 20 S/S CAPSCREW	-
23.	42-5461	SPIGOT SEALING WASHER	MUST BE CHANGED IF DISTURBED
24.	44-6637	60° CERAMIC DISC: HOT SIDE	'LEFT-TURN-CLOSE': NOTCH ON HEX
25.	23-5408	ACTUATOR SLEEVE	-
26.	42-5409	ACTUATOR SLEEVE O-RING	-
27.	20-5420	SPLINE ADAPTOR	-
28.	23-5410	TORQUE CONTROL MEMBER	'CLUTCH' PART
29.	42-3452	LEVER INTERFACE O-RING	-
30.	60-5417-C	DOUBLE LEVER LEFT	OBSOLETE (2023) - USE TBT3 LEVER
31.	42-5416	HUB CUSHIONING O-RING	2 PER SIDE REQUIRED (4 TOTAL)
32.	41-5419	LEVER RETAINING WASHER	-
33.	41-5414	LEVER RETAINING SCREW (M4x12)	TORX T20
34.	60-5411	ACTUATOR ENDCAP RED	-
35.	43-5462	PEX HOSE M10	OBSOLETE: LEGACY ORDERS ONLY
36.	43-5680	10MM FERRULE	2 REQUIRED
37.	43-5681	10MM COMPRESSION NUT	2 REQUIRED

*PREVIOUSLY WAS 23-5405 - NO LONGER AVAILABLE. TO REPLACE 23-5405, SUPPLY (14) & (15)

PART NO.	DESCRIPTION	COMMENTS
71-5693	NON-FLOWREG OUTLET FITTING	ASSY W/ O-RING. FITS INSTEAD OF (14) & (15)
60-5415-C	SHORT LEVER	OBSOLETE (2023)

ACCESSORIES

PART NO.	DESCRIPTION	COMMENTS
5492	FLUSHING KIT	-
5684	FLUSHING BOOT KIT	INCLUDES JUBILEE CLIP
5491	FULL TOOLKIT	-
23-6553	DEDICATED OUTLET FITTING KEY	21MM (FROM AUG 2018 - FOR 23-6531 OUTLET)
44-6076	DEDICATED OUTLET FITTING KEY	24MM (UP TO JULY 2018 - WITHOUT SHROUD)

SEE ALSO

SERVICE KITS

PART NO.	DESCRIPTION	COMMENTS
71-5489	LEVER MAINTENANCE KIT	INCLUDES PARTS MARKED WITH \$ ON SHEET 1
5969	O-RING KIT	INCLUDES PARTS MARKED WITH @ ON SHEET 1
71-5472	THERMOSTATIC CARTRIDGE	-
71-5471	THERMOSTATIC CARTRIDGE COVER	-
23-6531	6L/MIN OUTLET FITTING	SHROUD (15) NOT INCLUDED. SEE 71-6557 BELOW.

O-RING KIT INCLUDES STRAINER MESH BASKETS
 A "FULL SERVICE KIT", WOULD BE COMPOSED OF ITEMS 71-5489; 5969; 71-5472 AND 71-5471

CONVERSION KITS

PART NO.	DESCRIPTION	COMMENTS
71-5652	CONVERT 170 TO 200 LENGTH KIT	-
71-5653	CONVERT 170 TO 230 LENGTH KIT	-
5486	TAP WITHOUT SPIGOT (SHORT LEVERS)	-
5487	TAP WITHOUT SPIGOT (DUAL LEVERS)	TBT-1 OD1
70-5905	PAIR OF DUAL LEVERS	-
71-6557	OUTLET FITTING 23-6531 INCL. CHROME SHROUD	REPLACES 71-5648 (w/o Cr SHROUD)

PARTS SHOWN ON SHEET 1 - [TBT-3 BODY]

ALTERNATIVE PARTS NOT SHOWN ON SHEET 1

BALLOON	PART NO.	DESCRIPTION	COMMENTS
	60-5404	MAIN BOTTOM COVER	-
1.	42-5402	BODY SEAL O-RING	-
2.	71-5471	THERMOSTATIC COVER SUB-ASSY	NOW SUPPLIED SEPERATE FROM (4)
3.	71-5472	THERMOSTATIC CARTRIDGE	NOW SUPPLIED WITHOUT COVER (3)
4.	20-5435	TAP SECURING SCREW	-
5.	42-5429	SECURING SCREW O-RING	ALSO FOR BALL VALVE ACTUATOR
6.	71-5473	COLD INLET CARTRIDGE ASSY	LOWER CARTRIDGE NOW BRASS
7.	71-5474	HOT INLET CARTRIDGE ASSY	LOWER CARTRIDGE NOW BRASS
8.	43-5442	STRAINER MESH	-
9.	42-2482-B	REAR BODY SEAL O-RING	-
10.	44-6638	60° CERAMIC DISC: COLD SIDE	'RIGHT-TURN-CLOSE': NO MARKING
11.	60-5412	ACTUATOR ENDCAP BLUE	-
12.	60-6604	DOUBLE LEVER RIGHT	COLD SIDE - TBT3
13.	43-6635	FLOWREG OUTLET FITTING & SEAL	TBT3 FACE SEAL VERSION (6 L/MIN)
14.	----	-	-
15.	----	-	-
16.	----	BODY: NOT AVAILABLE AS SPARE	-
17.	71-5469	INTERCONNECT SUB-ASSEMBLY	170 NEEDS 2, 200 & 230 NEED 4
18.	71-5475-S	SPIGOT WITHOUT EXTENSION (170)	INCLUDES BIG NUT, NOT BEZEL
19.	60-5422-C	BEZEL	-
20.	71-5678	INLET COMPRESSION ADAPTOR	LEGACY PART ONLY.
21.	5433/5434	EXTENSION PIECE	5433 (SHORT:200), 5434 (LONG:230)
22.	41-5432	M5 x 20 S/S CAPSCREW	-
23.	42-5461	SPIGOT SEALING WASHER	MUST BE CHANGED IF DISTURBED
24.	44-6637	60° CERAMIC DISC: HOT SIDE	'LEFT-TURN-CLOSE': NOTCH ON HEX
25.	23-5408	ACTUATOR SLEEVE	-
26.	42-5409	ACTUATOR SLEEVE O-RING	-
27.	20-5420	SPLINE ADAPTOR	-
28.	23-5410	TORQUE CONTROL MEMBER	'CLUTCH' PART
29.	42-3452	LEVER INTERFACE O-RING	-
30.	60-6603	DOUBLE LEVER LEFT	HOT SIDE - TBT3
31.	42-5416	HUB CUSHIONING O-RING	2 PER SIDE REQUIRED (4 TOTAL)
32.	41-5419	LEVER RETAINING WASHER	-
33.	41-5414	LEVER RETAINING SCREW (M4x12)	TORX T20
34.	60-5411	ACTUATOR ENDCAP RED	-
35.	43-5462	PEX HOSE M10	OBSOLETE: LEGACY ORDERS ONLY
36.	43-5680	10MM FERRULE	2 REQUIRED
37.	43-5681	10MM COMPRESSION NUT	2 REQUIRED

PART NO.	DESCRIPTION	COMMENTS
43-6672	NON-FLOWREG OUTLET FITTING	NON REGULATED VERSION OF (14)

ACCESSORIES

PART NO.	DESCRIPTION	COMMENTS
5492	FLUSHING KIT	-
5684	FLUSHING BOOT KIT	INCLUDES JUBILEE CLIP
5491	FULL TOOLKIT	-
44-6666	DEDICATED OUTLET FITTING KEY	PLASTIC - FOR TBT3 FACE SEALING OUTLET
44-6667	UNIVERSAL OUTLET FITTING KEY	METAL - SUITABLE FOR TBT2 / 3 OUTLET FITTINGS

SEE ALSO

SERVICE KITS

PART NO.	DESCRIPTION	COMMENTS
71-5489	LEVER MAINTENANCE KIT	INCLUDES PARTS MARKED WITH \$ ON SHEET 1
6670	O-RING KIT	INCLUDES PARTS MARKED WITH @ ON SHEET 1
71-5472	THERMOSTATIC CARTRIDGE	-
71-5471	THERMOSTATIC CARTRIDGE COVER	-
43-6635	6L/MIN OUTLET FITTING	FACE SEAL FOR TBT3

O-RING KIT INCLUDES STRAINER MESH BASKETS
 A "FULL SERVICE KIT", WOULD BE COMPOSED OF ITEMS 71-5489; 6670; 71-5472 AND 71-5471

CONVERSION KITS

PART NO.	DESCRIPTION	COMMENTS
71-5652	CONVERT 170 TO 200 LENGTH KIT	-
71-5653	CONVERT 170 TO 230 LENGTH KIT	-
----	-	-
5487	TAP WITHOUT SPIGOT (DUAL LEVERS)	TBT-1 0DL
70-6671	PAIR OF DUAL LEVERS	-
----	-	-