



Horne Engineering Ltd
 Rankine Street
 Johnstone PA5 8BG
 Tel: 01505 321455
 technical@horne.co.uk
 www.horne.co.uk

HORNE T105A/106A/107A/108A THERMOSTATIC SHOWER PANEL FOR SURFACE MOUNTING WITH DUAL CONTROLS INSTALLATION, COMMISSIONING & MAINTENANCE INSTRUCTIONS

These instructions (L189) cover the HORNE range of pre-plumbed shower panels with ROTARY FLOW AND TEMPERATURE CONTROL. There are separate instructions for panels with push-button flow control (L-84, L-178), and others for panels with dual outlets and flow diverter valves (L-180, L-241).

0.1 Approvals

The TSV1-3 shower valve is independently tested & approved by an ISO 17025 Accredited Test House to all the requirements of Department of Health - HTM 04-01: Supplement *Performance Specification D 08: Thermostatic Mixing Valves (Healthcare Premises)*, to the following designations and for the following applications:

HP-S	Shower with supply pressures of 1 – 5 Bar and unrestricted flow rate
LP-SE	Shower with supply pressures of 0.2 – 1 Bar and unrestricted flow rate

The TSV1-3 is therefore classified as a Type 3 Thermostatic Mixing Valve according to HTM 04-01 Part A, and Health and Safety Executive HSIS6, 2012, document: Managing the risks from hot water and surfaces in health and social care.

The TSV1-3 also complies with Regulation 4 of the Water Supply (Water Fittings) Regulations 1999 and Water Bylaws (Scotland) 2014.

0.2 Backflow Prevention

The hot and cold inlets to the TSV1-3 valve are fitted with single in-line Water Reg. 4 approved DN15 Check Valves.

0.3 Supply Water Pressure Requirements

The minimum water pressure required to achieve a spray at the spray head is a dynamic head of 2m (3 psi, 0.2 bar) at the spray head. Note that for very low head installations, both hot and cold-water supplies must be at the same pressure.

Note that dynamic head is measured with the water running.

Where the TSV1-3 panel is fed by supplies with differing pressures, a pressure-reducing valve (PRV) may be required on the inlet with the higher pressure to prevent pulsing of the flow. Although this has minimal effect on thermostatic control, the flow pulsing is often considered undesirable.

Note that output flowrate is always determined by the lower of the two inlet pressures.

0.4 Operating Conditions Required for TMV Type 3 Compliant Installations

	High Pressure	Low Pressure
Maximum Static Pressure	10 Bar	10 Bar
Flow Pressure, Hot & Cold	1 to 5 Bar	0.2 to 1 Bar
Hot Water Supply Temperature	55 – 65°C	55 – 65°C
Cold Water Supply Temperature	5 – 20°C	5 – 20°C
Minimum Temperature Differential (Hot/Mixed, Mixed/Cold)	5K (=5°C)	5K (=5°C)

OUTSIDE OF THESE CONDITIONS THE TSV1-3 CANNOT BE EXPECTED TO OPERATE AS A TYPE 3 VALVE.

0.5 Temperature Adjustment Range

The mixed water temperature can be adjusted from cool through to a top limit (which can be pre-set during installation – factory set to approx. 41°C - with full anti-scald protection throughout the range).

0.6 Water and Energy Conservation

The TSV1 range shower panels are factory-fitted with flow regulators at the shower outlet to reduce the flow rate and conserve water and energy. The drawings at the end of this document provide information for accessing the flow restrictors/regulators for removal or replacement.

0.7 Alternative Water Entry

Note that panels with rear water-entry, with flexible soft-PEX hoses are also available. More specific instructions for installation of these panels is given at the end of the installation section.

SECTION 1: INSTALLATION

The surface mounting enclosure is supplied with fixings to attach it to a wall. However, consideration should be given to the type of wall fittings required, as different substrates will require different fittings. It is the responsibility of the installer to ensure that the fixings used are appropriate for the wall substrate.

The hot pipe is on the left, and cold on the right, when viewed from the user's perspective.

1.1 Recommended Mounting Heights – Guidance Only

T105, T107, T1Y7, T108, T1Y8 Panels	Support screw should be 2.0 metres from finished floor level*.
T106 Panel (swivel-head, shown p13)	Support screw should be 2.1 metres from finished floor level.

* For accessible and Changing Places installations, please refer to Building Regulations Doc M and BS8300 for appropriate guidance.

1.2 Mark the position for the panel

Identify a suitable position for the pre-plumbed enclosure and mark a spot for the support screw on the wall on the intended centreline of the panel, at the height indicated in the table above.

1.3 Install the Support Screw

Drill a hole in the wall and insert a wall plug and screw (7mm hole if using the supplied plug), leaving the head of the screw protruding approximately 12mm from the wall. Note that a corrosion resistant stainless-steel screw is supplied for this purpose.

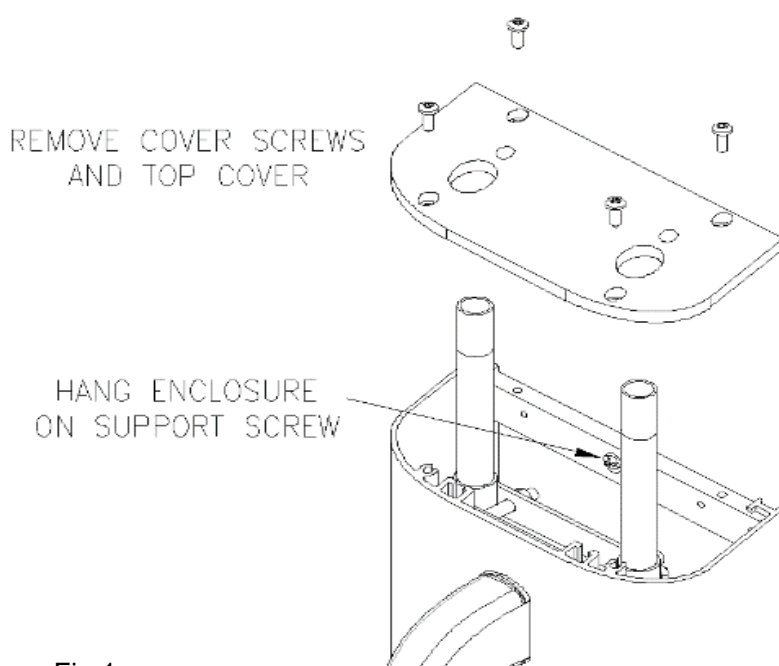

Fig.1

1.4 Hang the Enclosure on the Support Screw

Except where the panel includes an integral ILTDU (T4 or T9 variants), release the top cover of the pre-plumbed enclosure by removing the four screws. Hang the pre-plumbed enclosure on the support screw by the larger hole in the middle of the back strap and let this take the weight of the enclosure.

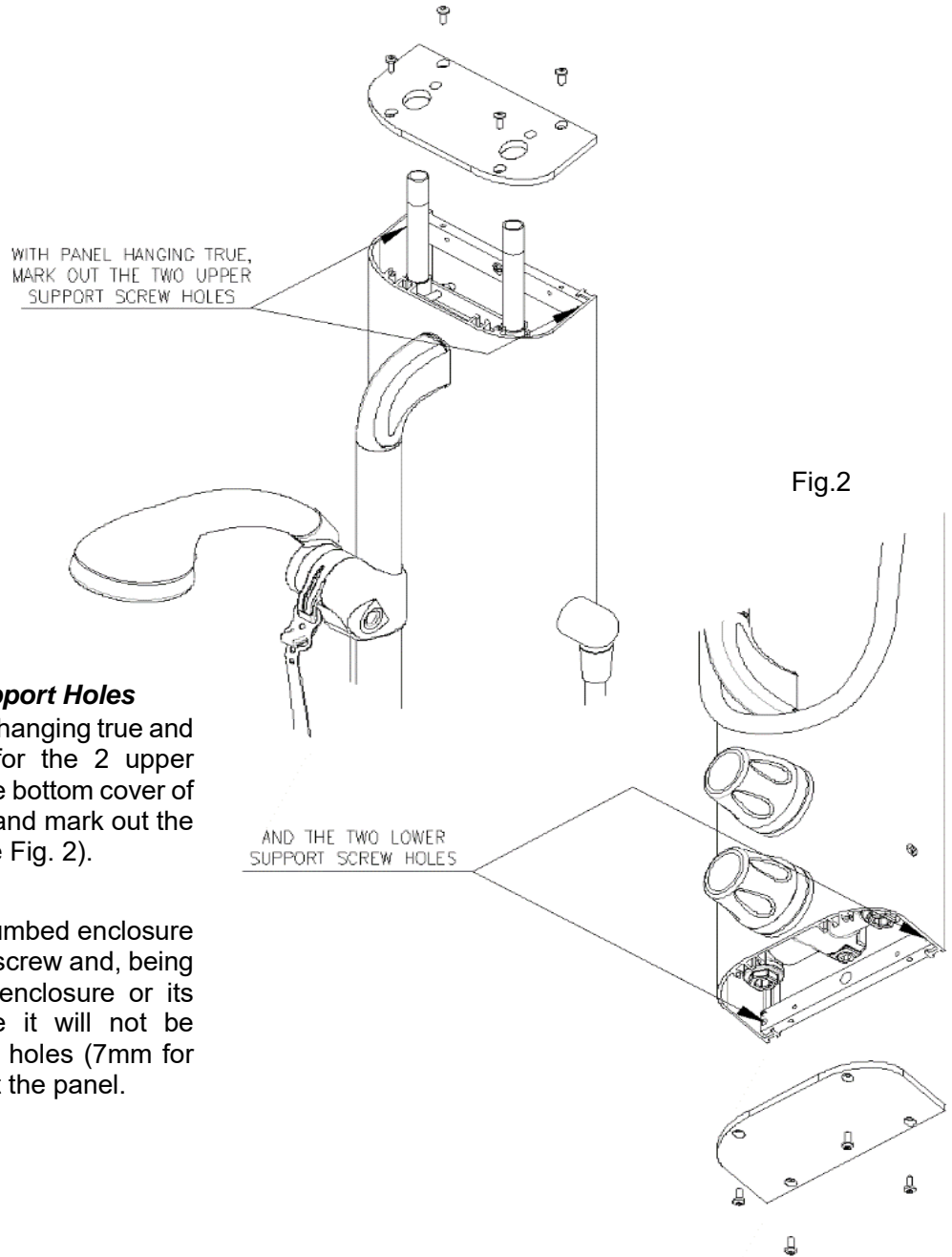

Fig.2

1.5 Mark out the Four Support Holes

Ensure that the enclosure is hanging true and then mark out the holes for the 2 upper support screws. Remove the bottom cover of the pre-plumbed enclosure and mark out the 2 lower support screws (See Fig. 2).

1.6 Drill Support Holes

Carefully remove the pre-plumbed enclosure from the temporary support screw and, being careful not to scratch the enclosure or its covers, lay it down where it will not be damaged. Drill 4 x support holes (7mm for the supplied plugs) to mount the panel.

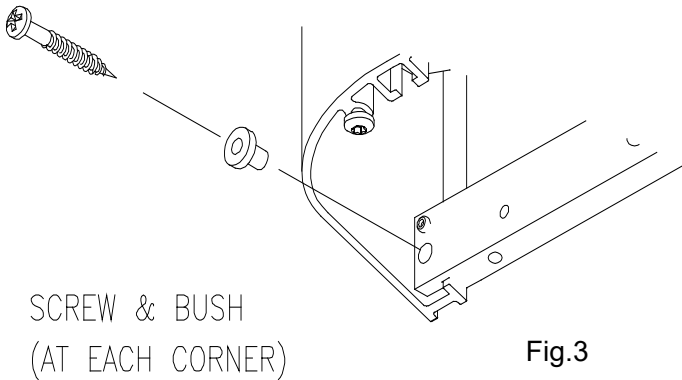

Fig.3

1.7 Attach the Unit to the Wall

Carefully re-hang the pre-plumbed enclosure on the temporary screw. Put the 4 supplied screw bushes in the mounting holes in the panel and then attach the panel firmly to the wall using 4 stainless-steel screws. A bead of silicon mastic can be used, if required, to cover any gaps behind the panel on uneven walls. Do not mastic the lower End Cap to the wall.

N.B. It is important to use the supplied screw bushes.

1.8 Connect the Supply Pipes

N.B. Except where the panel includes an integral ILTDU, ensure that the top cover of the pre-plumbed enclosure is replaced prior to connecting up the supply pipes. The fitting of isolation valves is required as close as practicable to the water supply inlets of the shower panel.

Connect the hot water supply to the left-side inlet, and cold water to the right-side inlet (See Fig. 4).

DO NOT OPEN THE WATER SUPPLIES AT THIS STAGE AS THEY HAVE NOT BEEN FLUSHED OUT TO REMOVE THE DEBRIS IN THE PIPEWORK. SUCH DEBRIS CAN DAMAGE THE THERMOSTATIC VALVE

1.9 Flush the Pipework

Flushing is required by Water Fittings Regulations 1999, schedule 2 G13.1, the Water Bylaws 2014 (Scotland) and BSEN 806 and is also essential for the function of the shower valve. The most common cause for complaint regarding the performance of any Thermostatic Mixing Valve is traced to dirt or debris in the TMV or check valves.

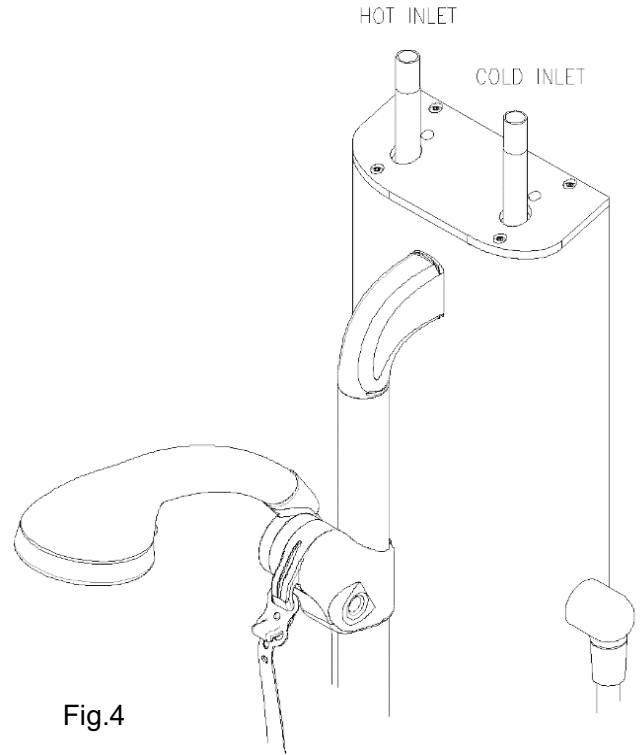

Fig.4

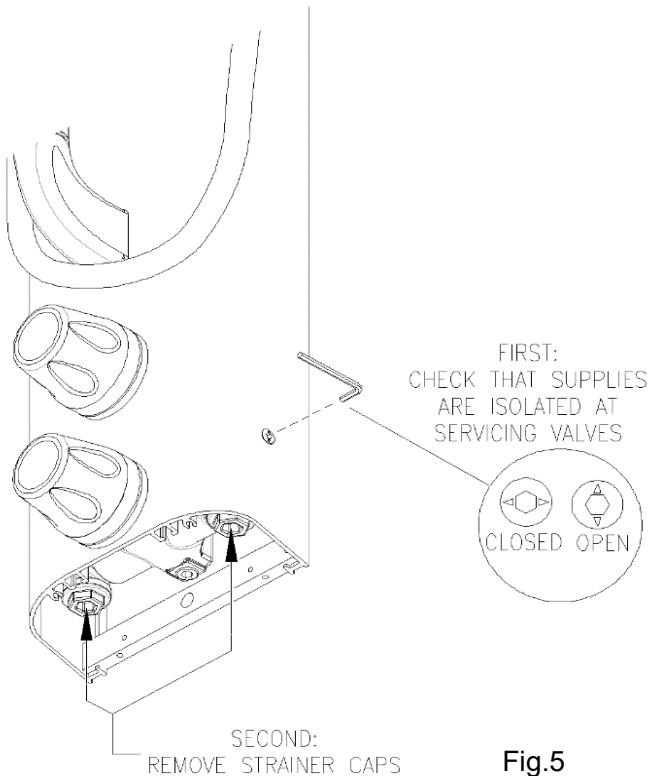

Fig.5

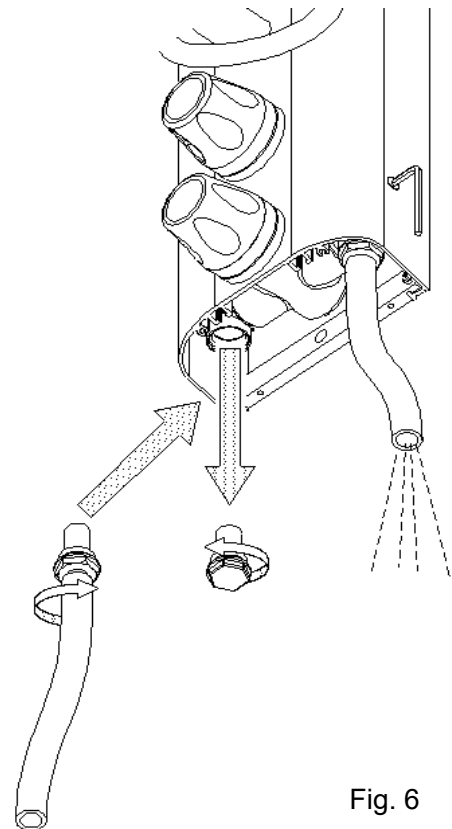

Fig. 6

Access to the flushing points is gained from underneath the casing through the lower end cap. Isolate the water using the low-level servicing valves located on the side of the panel (Fig. 5) using a 4mm hex key. Remove the strainer cap with the strainer basket and screw in the flushing adapter. Place the end of the flushing hose in a drain or container and turn on the supply to flush AT FULL BORE until any pipework that has been worked on is cleared. After flushing, remove the flushing adapter and replace the strainer cap. Repeat for both hot and cold supplies. See Fig. 5 and 6.

NOTE THAT IF THE SYSTEM IS NOT TO BE COMMISSIONED IMMEDIATELY AND/OR THERE IS ANY DANGER OF FREEZING THEN THE PIPES AND VALVE MUST BE DRAINED TO AVOID DAMAGE. OPEN THE STRAINER CAPS FOR THIS PURPOSE.

1.10 Test for Leaks in Pipework

Ensure that the TSV1-3 on/off control is closed (turned fully clockwise) and open the supplies. Open the servicing valves on the TSV1 casing (See Fig. 5). Open the supplies to the panel, adjust the temperature control and check for any water leaks upstream of the thermostatic valve. Make good any leaks found. The valve is now ready for commissioning.

Note that if the controls, enclosure and shower accessories require cleaning then care must be taken not to scratch them in the process. Wash off any surface dust with the shower spray before cleaning with soapy water.

DO NOT USE ANY ABRASIVE CLEANERS OR SOLVENTS OR THE SURFACES MAY BE DAMAGED.

1.11 Supplementary Installation Instructions for ...B Variants [Hose Inlets from Rear].

TSV1 shower panels are available in versions with flexible braided stainless steel inlet hoses rather than top entry copper pipework. The hoses used are UK Water Reg 4 Approved SOFT-PEX (cross-linked polyethylene). They are not EPDM lined. These shower versions have Product Reference codes with the suffix B, e.g. T108B.

The main difference, from an installation point of view, is that the water supplies may have to be connected before the pre-plumbed enclosure is attached to the wall. Accordingly, point 7 on the attached installation instructions (Connect the Supply Pipes) should be performed before point 6 (Attach the Pre-Plumbed panel to the Wall) unless alternative access is available to the connections, e.g. via an access panel.

Note that the braided hose inlets are colour coded with BLUE for the Cold Water Supply and RED for the Hot Water Supply.

Care should be taken to ensure that the weight of the pre-plumbed enclosure is taken by the mounting screws and NOT by the hoses.

SECTION 2: COMMISSIONING

NB: THE TSV1 CANNOT BE COMMISSIONED UNTIL HOT AND COLD WATER ARE AVAILABLE.

Commissioning the unit involves flushing the water supply; setting the temperature; and finally performing a cold-water isolation test to confirm the safe operation of the thermostatic valve as fitted. Flushing is included in the Installation section to ensure it is done as soon as possible after installation but should be considered vital to the commissioning process. Commissioning is essential to establish a reference point for future in-service tests, and to ensure the thermostatic valve works correctly under site conditions.

2.1 Flushing

Unless you are absolutely certain that this has been done, flush the pipework: see section 1.9 above.

2.2 Pre-Checks

Ensure that the NHS designation of the valve matches the intended application, that both hot and cold-water supplies are open and at, or near, their design temperatures and pressures, and that they are within the Type 3 TMV requirements of the valve as outlined in section 0.4. Also ensure that the servicing valves are open.

2.3 Temperature Setting

The TSV1-3 is set in the factory to verify correct thermostatic performance, but this must be checked on site during commissioning to ensure that the site conditions do not impair the operation of the valve. If necessary, reset the maximum outlet temperature to 41°C as stated in table 2 of HTM 04-01 D 08 supplement.

- 2.3.1 Set the temperature control to the maximum temperature setting (rotate the control anticlockwise until it stops).
- 2.3.2 Fully open the on/off control by turning it anticlockwise. For installations with a fixed shower head, putting a burst polythene bag over the shower head will help to catch and deflect the spray during commissioning.

2.3.3 Allow the shower to run at maximum temperature setting until the water temperature has stabilised. Should the temperature rise, or drop, in an uncontrolled fashion, then the hot and cold supplies are probably reversed. Correct this before proceeding.

2.3.4 During commissioning, the valve **MUST** be adjusted **DOWN** to temperature. This is to ensure that the hot water system is capable of supplying water, at the working flowrate, in excess of the required outlet temperature by a margin of at least 5°C. Note that this is not always the case with instantaneous water-heaters. To do this, set the valve to 5°C higher than required; measure and confirm the elevated temperature, and then reduce the temperature to the required level. If the valve cannot be set to 5°C higher than required, then the outlet temperature is being controlled by the inlet conditions and not safely by the valve, therefore the commissioning is not complete, and **VULNERABLE USERS SHOULD NOT BE ALLOWED TO OPERATE THE SHOWER.**

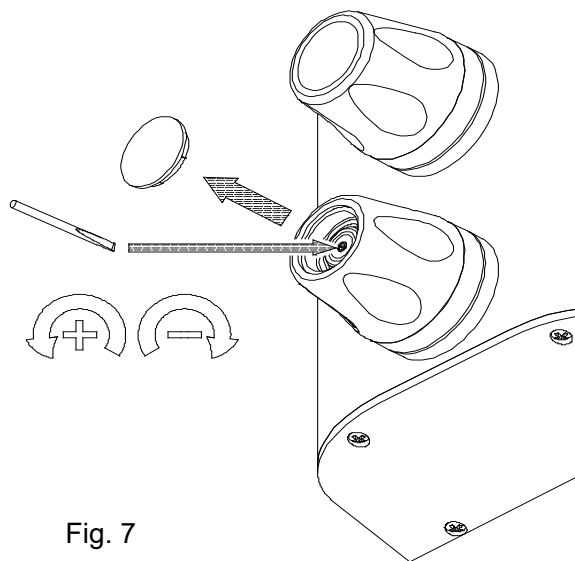

Fig. 7

2.3.5 To adjust the set maximum temperature, remove the temperature control cap (prize plastic ones off using a small screwdriver; or unscrew the metal ones - Horne tool 23-5459 or nitrile gloves are helpful for grip) and adjust the small, slotted screw in the centre of the spindle. Adjust the screw anticlockwise to increase the temperature, clockwise to decrease the temperature. See Fig. 7.

2.3.6 After setting the maximum temperature on the knob, turn the shower on and off a few times and check that the maximum setting is correct.

2.4 D08 Compliance

Note that, to comply with D08, the final stabilised Mixed Water Temperature should not exceed 43°C. Record the commissioning information, including equipment used, on the attached commissioning sheet to permit the in-service performance of the valve to be assessed in the future.

2.5 Cold Isolation Test

2.5.1 Finally, check the thermal shut-off facility of the TSV1-3 by performing a Cold Isolation Test (sometimes colloquially called a “fail-safe” test) as follows. With the shower running full, close the cold (i.e. right side) servicing valve. [The Servicing Valve is closed when the arrows are in the horizontal position, and open when they are in the vertical position: see Fig. 5]. If there is any flow after 5 seconds, this must amount to no more than 120ml in 60 seconds of collecting. If there is more than this amount, find possible corrective actions in the “Maintenance” section below. If the Cold Isolation Test is satisfactory, restore the supply and note the final stabilised temperature in the commissioning log. This should be within 2°C of the original temperature, and must not exceed 43°C. Generally, the mixed water temperature should not rise by more than 2.9°C during this cold-water isolation test. Record the result of this on the attached commissioning sheet.

Failure of the Cold Isolation Test at commissioning is usually due to dirt particles having migrated into the valve from the pipework. This is why flushing is essential.

Note that the incoming hot-water temperature must be maintained in the range described in the table at the bottom of page 1 for this test to be valid. Refer to the maintenance section of this booklet or phone the factory for advice, if necessary.

For installations with a fixed shower head, putting a burst polythene bag over the shower head will help to catch and deflect the spray and avoid getting wet.

2.6 Test the Check-Valves

Although check-valve failures are rare, verifying their operation at commissioning time in a large installation can give peace of mind later. Refer to section 3.8 .

SECTION 3: MAINTENANCE

Maintenance of all Thermostatic Mixing Valves is essential to ensure the product continues to perform to specification after installation and continues to afford scald protection. Record all maintenance carried out on the attached commissioning and maintenance record.

3.1 In-Service Testing

Periodic testing should be carried out to check whether any deterioration has occurred in the performance of the shower valve. The results of these tests, and the equipment used, should be recorded on the Commissioning, Maintenance and In-Service Testing Sheet at the back of these instructions. Fill in all the parameters requested on the sheet.

Note that instrumentation to the same specification should be used each time when measurements are taken to ensure consistency of results. Record all the information on the In-Service Testing sheet at the back of these instructions.

Also record any requirement to adjust the Mixed Water Temperature on the in-service testing record.

NOTE: A THERMOSTATIC MIXING VALVE IN NEED OF MAINTENANCE CAN BE UNDETECTABLE IN NORMAL USE AND ONLY BECOME APPARENT WHEN DISRUPTION OCCURS IN THE HOT OR COLD-WATER SUPPLY TEMPERATURES OR PRESSURES. IN SERVICE TESTING SHOULD BE CARRIED OUT AT A FREQUENCY DETERMINED BY LOCAL RISK ASSESSMENT TO DETECT ANY SUCH DETERIORATION.

3.2 Routine Servicing

- 3.2.1 Replace the “O” rings every three years (Maintenance kit with spare “O” rings available). It is especially important to replace the slide-valve seal, located in a groove in the valve body. Horne tools Part No. 4411 are helpful for this job. See the Horne website “maintenance” section for further instruction and videos.
- 3.2.2 Replace the Thermostat Element every 6 years, or more often if problems are experienced or in installations where the water is aggressive.
- 3.2.3 Replace the slide-valve assembly if it becomes damaged. This may happen due to scale or grit in the water.
- 3.2.4 The multi-turn On/Off mechanism should be replaced if it leaks. Ensure the on/off assembly is torqued down to 25 Nm (18Lbf.ft) on re-fitting to prevent the user from inadvertently unscrewing the assembly during flow control. Do not over tighten the assembly. Lever options use a 60-degree rotation ceramic disc cartridge, which should be replaced if it leaks.

3.3 Strainer Baskets

Initially check the strainer baskets for debris every three months and clean if required. This period can perhaps be increased later if it is established that the water is generally clean and free of debris.

3.4 Cold Isolation Test - Corrective Actions for Failure

- 3.4.1 Regularly perform a Cold Isolation Test and check the maximum temperature setting as described in the “Commissioning” section 2.5 above. If the valve fails this test then consider the following:
- 3.4.2 Perform an Isolation Test, but shut the hot instead of the cold. If this results in a similar rate of flow as when shutting the cold then consider that there may be a problem with the slide-valve seal. Follow the routine servicing instructions above, section 3.2.1.
- 3.4.3 Opening and cleaning the valve can cure problems caused by dirt in the pipework that has migrated into the valve, but note that if water cleanliness is poor, or flushing is not carried out, then dirt can damage the slide-valve knife-edge faces. This will necessitate replacement of the slide-valve.
- 3.4.4 Cleaning/dressing of the hot valve seat may be necessary if the valve is old and/or scaled. This can be done with Horne tool 5395, and some toothpaste or fine grinding paste.
- 3.4.5 Failure of the Cold Isolation Test can be caused by hot water in the cold supply: test the check-valves.
- 3.4.6 In the water supply is ‘hard’, then de-scaling of the valve may be necessary. See section 3.6.

3.5 Notes on Dismantling

- 3.5.1 All internal components of the thermostatic valve can be removed from the front of the panel by removing the components shown in drawing TSV1-3-C below. There is no need to remove the panel from the wall unless you wish to remove the valve from the panel, to de-scale it for example.
- 3.5.2 Treat all parts with care when removing them from the valve body. Note especially that the slidevalve is a precision component and can easily be damaged.
- 3.5.3 Do not forget the slide-valve seal, partially hidden in a groove in the valve-body. Horne tool 4411 can be used to remove it. Be careful not to scratch the groove sides whilst removing the seal. This and all other plastic/rubber parts must be removed before de-scaling.

3.6 Notes on Descaling (see drawings TSV1-3-C below)

- 3.6.1 If the valve body requires de-scaling, first remove the valve from the panel (see section 3.9). Remove all o-ring seals and internal parts, then use a proprietary de-scaling fluid. Do not put the thermostat element or any plastic/rubber parts in de-scaling fluid.
- 3.6.2 Inspect the condition of the "Hot Valve Face", with which the knife-edge of the slide-valve mates, and the "Cold Valve Face". If the valve faces show signs of deterioration, they can be resurfaced as follows.
 - ◇ Re-surface the Hot Valve Face using a mandrel (Horne part no. 5395) and a water-soluble scouring paste (toothpaste works quite well).
 - ◇ Use P800 Grade wet abrasive paper on a flat surface to smooth the "Cold Valve Face" (ie, the lower face of the valve cover assembly with which the slide-valve mates).
- 3.6.3 Prior to re-assembly of the valve, ensure it is clean and all debris is removed.

3.7 Notes on Re-assembly

- 3.7.1 Make sure all components are clean before re-assembly. It is recommended to fit new o-rings.
- 3.7.2 Ensure the slide-valve seal is fitted in the body and is in good condition.
- 3.7.3 Smear silicon oil (not grease) on all "O" rings prior to installation. Also lightly smear the outside diameter of the slide-valve with silicon oil before fitting.
- 3.7.4 Fit the remaining components into the valve body using drawing TSV1-3-C (below) as a guide.
- 3.7.5 For optimal thermostatic performance, orient the visible tail end of the return spring towards the left side (hot inlet side) before inserting the slide-valve. Then turn the thermostatic adjustment to the full cold position *before* screwing on the cover.
- 3.7.6 Torque the TSV1-3 cover to 40 Nm (29Lbf.ft). This is to prevent the user from inadvertently unscrewing the cover during temperature adjustment. Do not over tighten the cover.
- 3.7.7 After any dismantling of the valve, perform a Cold Isolation Test per section 2.5 to verify correct re-assembly.

3.8 Testing of Check-Valves

The Check Valves prevent crossflow between hot and cold-water supplies under unequal pressure conditions and are designed for long life with no maintenance. Their function can be tested as follows:

- 3.8.1 Start with the outlet to the valve closed and both hot and cold isolating valves open.
- 3.8.2 To test the Check Valve on the hot side, shut off the hot supply and ensure the cold supply is open. Be prepared for leakage of trapped water from the pipe and remove the strainer basket on the hot side. Any continuing leakage evident from the strainer body is likely to be coming through the hot supply Check Valve (N.B. Ensure the hot isolating valve shuts off tightly, or it may cause leakage here). Testing of the cold-side check valve is a mirror of this process.
- 3.8.3 If either Check Valve is passing, then the inlet elbow (complete with Check Valve and strainer basket) should be replaced. It is not possible to satisfactorily remove the Check Valve itself from the inlet elbow and this should not be attempted. The shower valve body must be removed from the pre-plumbed enclosure to remove the inlet elbows. Pay attention to the section below on "removal of valve from panel", and fig.8.

3.9 Removal of Valve from Panel

If removing the valve from the panel, for example for descaling, then care should be taken over the low-level isolation actuators, which are connected to the valve via spring-loaded Oldham drive couplings.

The 2 parts of the coupling can be held together by M2 screws (part no 41-5667) inserted down the 4mm hex hole, to prevent loss of the very small springs during assembly & disassembly.

3.10 External Cleaning

When cleaning the external levers or control knobs, use only a soft cloth and soap. Never use cleaners containing abrasives or solvents as they may damage the chrome plating.

3.11 Frequency Of Testing

The frequency of in-service testing depends upon the condition of the water passing through the TSV1-3. In-service testing must be carried out more frequently in hard water areas than in soft water areas. As a general guide, in-service testing should be carried out at intervals somewhere between 6 and 12 months. In-service testing should be carried out at least every 12 months and, where the water is hard, the interval may be less than 6 months. Experience of local conditions and the in-service testing record will dictate the required frequency of in-service testing. In the absence of practical experience of this, a first check 6 – 8 weeks after commissioning should be performed. If no problems are detected (and mixed water temp is within 1°C of the commissioning temp) then checking again 12 – 15 weeks after commissioning to help build up a history. The results should be recorded on the attached sheet. Any requirement to reset the mixed water temperature should be noted. If no such adjustments are required, then the next in-service tests can be scheduled for 24 – 28 weeks after commissioning. If small adjustments (1 to 2K) are required then check the strainers for cleanliness, make sure the isolating valves are fully open and verify the check valves are operating correctly (see Maintenance Section). The next in-service test should be conducted 18 - 21 weeks after commissioning. If larger adjustments are required (>2K), then service work is required, and the in-service tests should be repeated 18 – 21 weeks after commissioning. Note that the pressure and temperatures of the supplies must be identical to those during commissioning for the in-service tests to be meaningful.

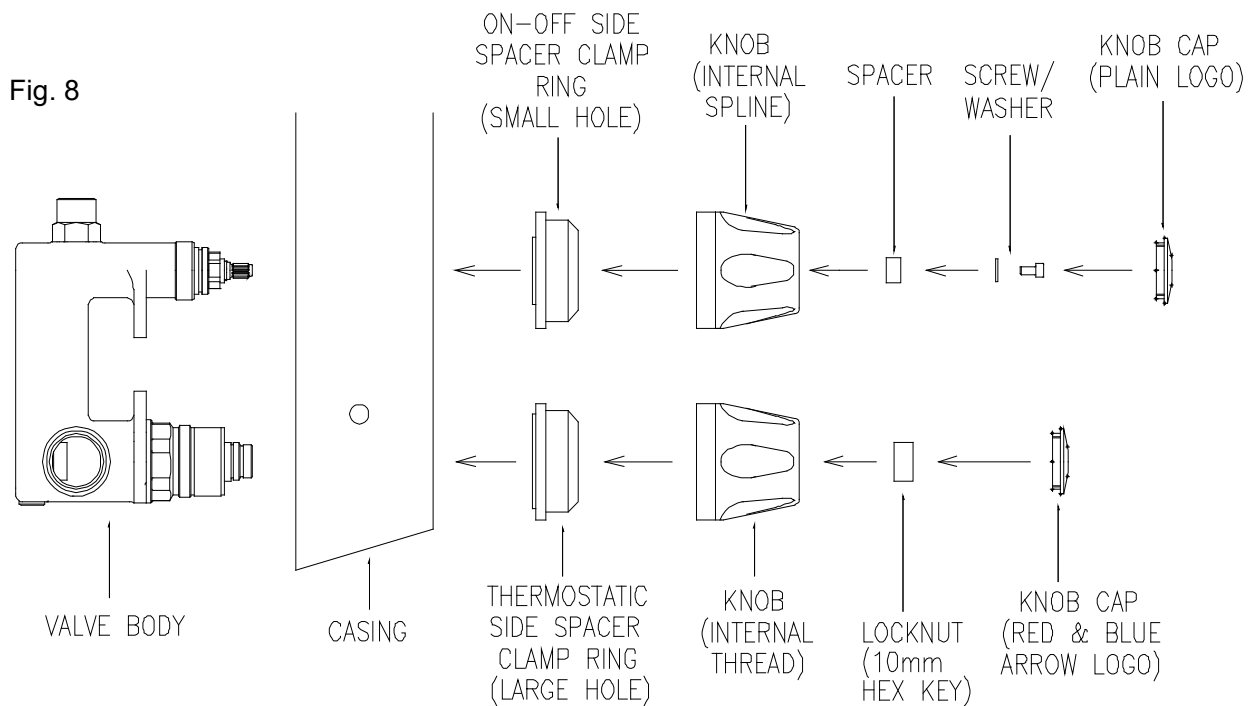

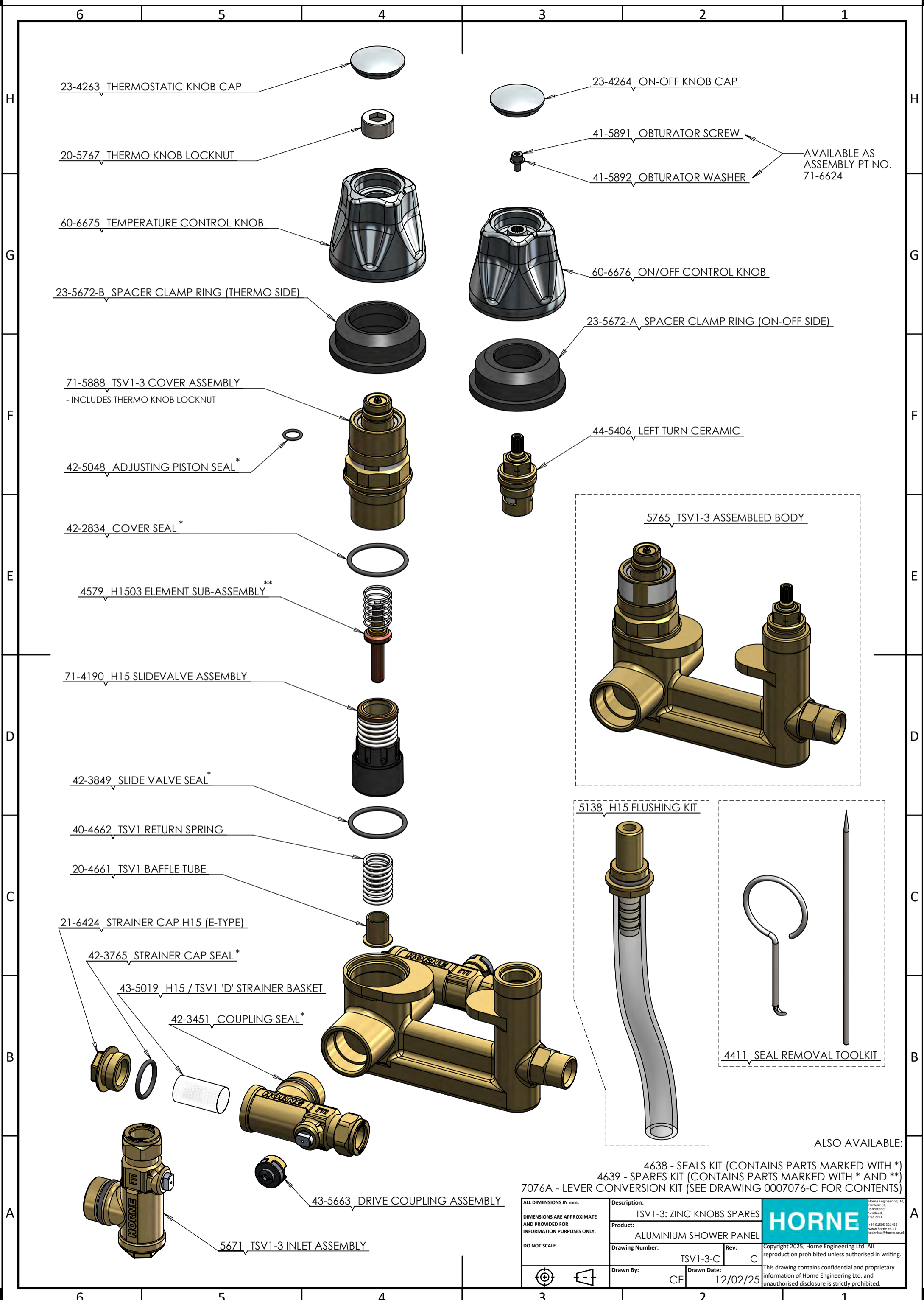

23-4263 THERMOSTATIC KNOB CAP

20-5767 THERMO KNOB LOCKNUT

60-6675 TEMPERATURE CONTROL KNOB

23-5672-B SPACER CLAMP RING (THERMO SIDE)

71-5888 TSV1-3 COVER ASSEMBLY
- INCLUDES THERMO KNOB LOCKNUT

42-5048 ADJUSTING PISTON SEAL*

42-2834 COVER SEAL*

4579 H1503 ELEMENT SUB-ASSEMBLY**

71-4190 H15 SLIDEVALVE ASSEMBLY

42-3849 SLIDE VALVE SEAL*

40-4662 TSV1 RETURN SPRING

20-4661 TSV1 BAFFLE TUBE

21-6424 STRAINER CAP H15 (E-TYPE)

42-3765 STRAINER CAP SEAL*

43-5019 H15 / TSV1 'D' STRAINER BASKET

42-3451 COUPLING SEAL*

43-5663 DRIVE COUPLING ASSEMBLY

5671 TSV1-3 INLET ASSEMBLY

23-4264 ON-OFF KNOB CAP

41-5891 OBTURATOR SCREW

41-5892 OBTURATOR WASHER

AVAILABLE AS
ASSEMBLY PT NO.
71-6624

60-6676 ON/OFF CONTROL KNOB

23-5672-A SPACER CLAMP RING (ON-OFF SIDE)

44-5406 LEFT TURN CERAMIC

5765 TSV1-3 ASSEMBLED BODY

5138 H15 FLUSHING KIT

4411 SEAL REMOVAL TOOLKIT

ALSO AVAILABLE:

4638 - SEALS KIT (CONTAINS PARTS MARKED WITH *)
4639 - SPARES KIT (CONTAINS PARTS MARKED WITH * AND **)
7076A - LEVER CONVERSION KIT (SEE DRAWING 0007076-C FOR CONTENTS)

ALL DIMENSIONS IN mm. DIMENSIONS ARE APPROXIMATE AND PROVIDED FOR INFORMATION PURPOSES ONLY. DO NOT SCALE.	Description:		
	Product:		
	Drawing Number:	Rev:	
	Drawn By:	Drawn Date:	
		TSV1-3-C	C
		CE	12/02/25

Copyright 2025, Horne Engineering Ltd. All reproduction prohibited unless authorised in writing. This drawing contains confidential and proprietary information of Horne Engineering Ltd. and unauthorised disclosure is strictly prohibited.

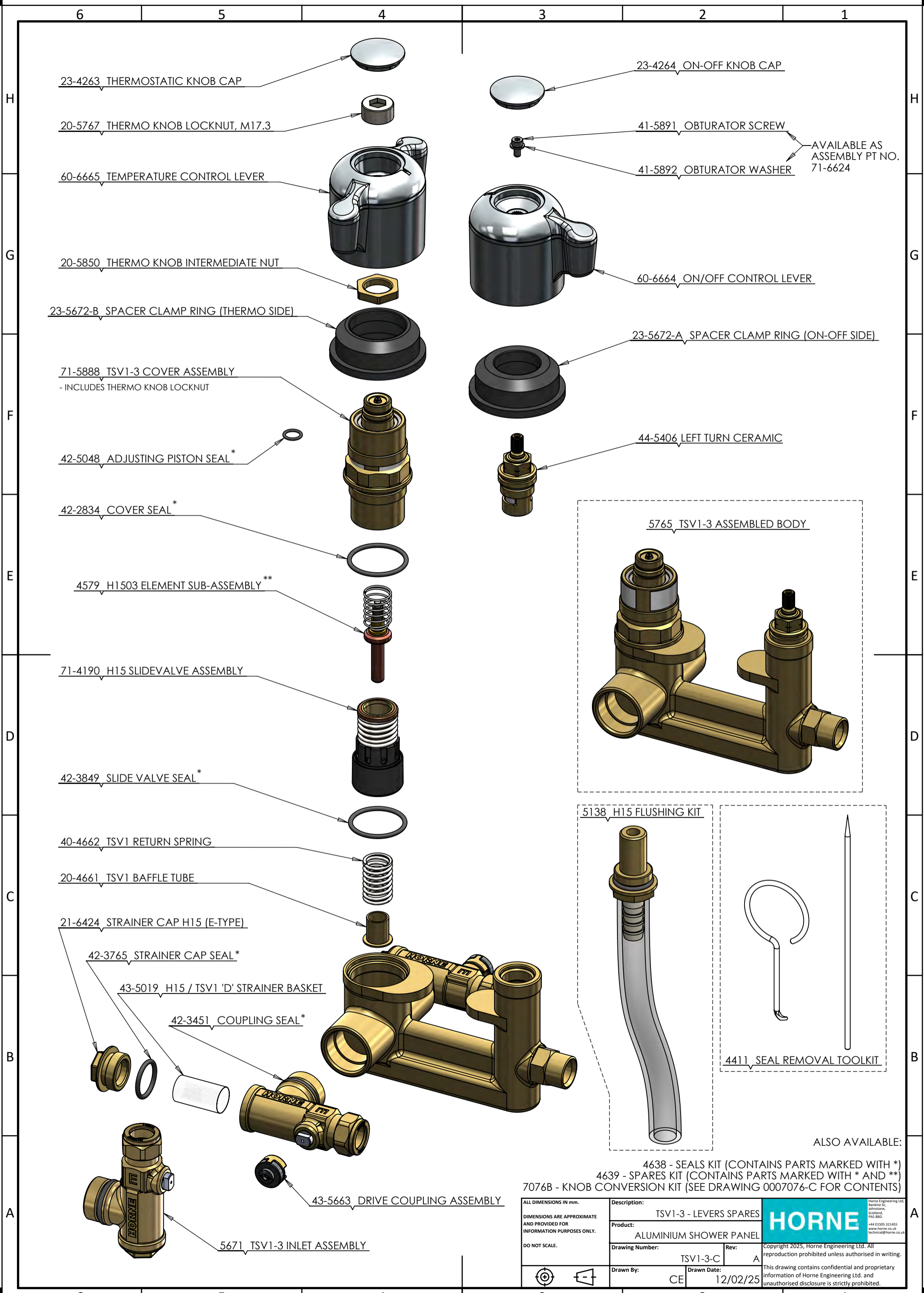

23-4263 THERMOSTATIC KNOB CAP

20-5767 THERMO KNOB LOCKNUT, M17.3

60-6665 TEMPERATURE CONTROL LEVER

20-5850 THERMO KNOB INTERMEDIATE NUT

23-5672-B SPACER CLAMP RING (THERMO SIDE)

71-5888 TSV1-3 COVER ASSEMBLY
- INCLUDES THERMO KNOB LOCKNUT

42-5048 ADJUSTING PISTON SEAL *

42-2834 COVER SEAL *

4579 H1503 ELEMENT SUB-ASSEMBLY **

71-4190 H15 SLIDEVALVE ASSEMBLY

42-3849 SLIDE VALVE SEAL *

40-4662 TSV1 RETURN SPRING

20-4661 TSV1 BAFFLE TUBE

21-6424 STRAINER CAP H15 (E-TYPE)

42-3765 STRAINER CAP SEAL *

43-5019 H15 / TSV1 'D' STRAINER BASKET

42-3451 COUPLING SEAL *

43-5663 DRIVE COUPLING ASSEMBLY

5671 TSV1-3 INLET ASSEMBLY

23-4264 ON-OFF KNOB CAP

41-5891 OBTURATOR SCREW

41-5892 OBTURATOR WASHER

AVAILABLE AS
ASSEMBLY PT NO.
71-6624

60-6664 ON/OFF CONTROL LEVER

23-5672-A SPACER CLAMP RING (ON-OFF SIDE)

44-5406 LEFT TURN CERAMIC

5765 TSV1-3 ASSEMBLED BODY

5138 H15 FLUSHING KIT

4411 SEAL REMOVAL TOOLKIT

ALSO AVAILABLE:

4638 - SEALS KIT (CONTAINS PARTS MARKED WITH *)
4639 - SPARES KIT (CONTAINS PARTS MARKED WITH * AND **)
7076B - KNOB CONVERSION KIT (SEE DRAWING 0007076-C FOR CONTENTS)

ALL DIMENSIONS IN mm. DIMENSIONS ARE APPROXIMATE AND PROVIDED FOR INFORMATION PURPOSES ONLY. DO NOT SCALE.	Description: TSV1-3 - LEVERS SPARES		 Horne Engineering Ltd. Rankine St, Johnstone, Scotland, PA8 8BD. +44 (0)1505 321455 www.horne.co.uk technical@horne.co.uk
	Product: ALUMINIUM SHOWER PANEL		
	Drawing Number: TSV1-3-C	Rev: A	
	Drawn By: CE	Drawn Date: 12/02/25	

Copyright 2025, Horne Engineering Ltd. All reproduction prohibited unless authorised in writing. This drawing contains confidential and proprietary information of Horne Engineering Ltd. and unauthorised disclosure is strictly prohibited.

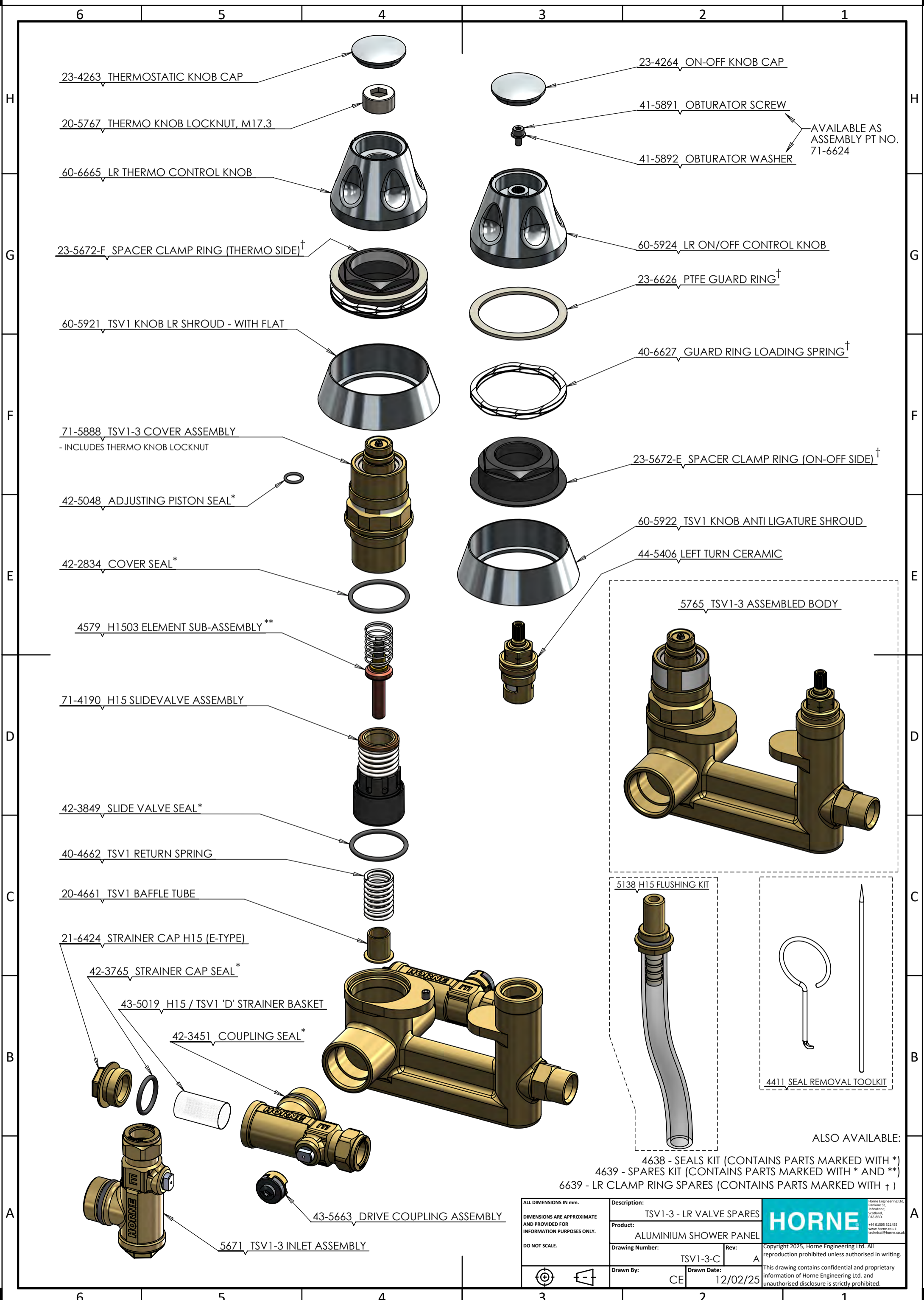

23-4263 THERMOSTATIC KNOB CAP

20-5767 THERMO KNOB LOCKNUT, M17.3

60-6665 LR THERMO CONTROL KNOB

23-5672-F SPACER CLAMP RING (THERMO SIDE)[†]

60-5921 TSV1 KNOB LR SHROUD - WITH FLAT

71-5888 TSV1-3 COVER ASSEMBLY
- INCLUDES THERMO KNOB LOCKNUT

42-5048 ADJUSTING PISTON SEAL*

42-2834 COVER SEAL*

4579 H1503 ELEMENT SUB-ASSEMBLY**

71-4190 H15 SLIDEVALVE ASSEMBLY

42-3849 SLIDE VALVE SEAL*

40-4662 TSV1 RETURN SPRING

20-4661 TSV1 BAFFLE TUBE

21-6424 STRAINER CAP H15 (E-TYPE)

42-3765 STRAINER CAP SEAL*

43-5019 H15 / TSV1 'D' STRAINER BASKET

42-3451 COUPLING SEAL*

43-5663 DRIVE COUPLING ASSEMBLY

5671 TSV1-3 INLET ASSEMBLY

23-4264 ON-OFF KNOB CAP

41-5891 OBTURATOR SCREW

41-5892 OBTURATOR WASHER

AVAILABLE AS
ASSEMBLY PT NO.
71-6624

60-5924 LR ON/OFF CONTROL KNOB

23-6626 PTFE GUARD RING[†]

40-6627 GUARD RING LOADING SPRING[†]

23-5672-E SPACER CLAMP RING (ON-OFF SIDE)[†]

60-5922 TSV1 KNOB ANTI LIGATURE SHROUD

44-5406 LEFT TURN CERAMIC

5765 TSV1-3 ASSEMBLED BODY

5138 H15 FLUSHING KIT

4411 SEAL REMOVAL TOOLKIT

ALSO AVAILABLE:

- 4638 - SEALS KIT (CONTAINS PARTS MARKED WITH *)
- 4639 - SPARES KIT (CONTAINS PARTS MARKED WITH * AND **)
- 6639 - LR CLAMP RING SPARES (CONTAINS PARTS MARKED WITH †)

ALL DIMENSIONS IN mm. DIMENSIONS ARE APPROXIMATE AND PROVIDED FOR INFORMATION PURPOSES ONLY. DO NOT SCALE.	Description:		
	Product:		
	Drawing Number:	Rev:	
	Drawn By:	Drawn Date:	
		TSV1-3 - LR VALVE SPARES	Copyright 2025, Horne Engineering Ltd. All reproduction prohibited unless authorised in writing. This drawing contains confidential and proprietary information of Horne Engineering Ltd. and unauthorised disclosure is strictly prohibited.
		ALUMINIUM SHOWER PANEL	
		TSV1-3-C A	
		CE 12/02/25	

TO REMOVE FLOW REGULATOR

- 1> REMOVE THE 2 CAPHEAD SCREWS (USING 3MM HEX KEY)
- 2> PRISE SPRAYPLATE OUT WITH A BLADE OR SIMILAR
- 3> REMOVE THE RETAINING RING
- 4> REMOVE FLOW REGULATOR WITH ITS O-RING

STEPS <3> AND <4> CAN BE DONE BY TURNING ON THE WATER SUPPLY AND CATCHING THE PARTS IN A BUCKET

TO RE-FIT FLOW REGULATOR

- 1> INSERT FLOWREG INTO HOLE, FLANGED SIDE UP (FACING THE WATER SUPPLY)
- 2> PUSH O-RING INTO GAP AROUND FLOWREG
- 3> INSERT RETAINING RING
- 4> FIT THE LARGE O-RING ONTO THE SPRAYPLATE AND FIT THE SPRAYPLATE
- 5> RE-FIT THE CAPHEAD SCREWS

NOTE THAT THE SPRAY PLATE CAN BE FITTED IN 2 DIFFERENT ORIENTATIONS TO ALLOW GREATER OR LESSER 'THROW' OF THE WATER.

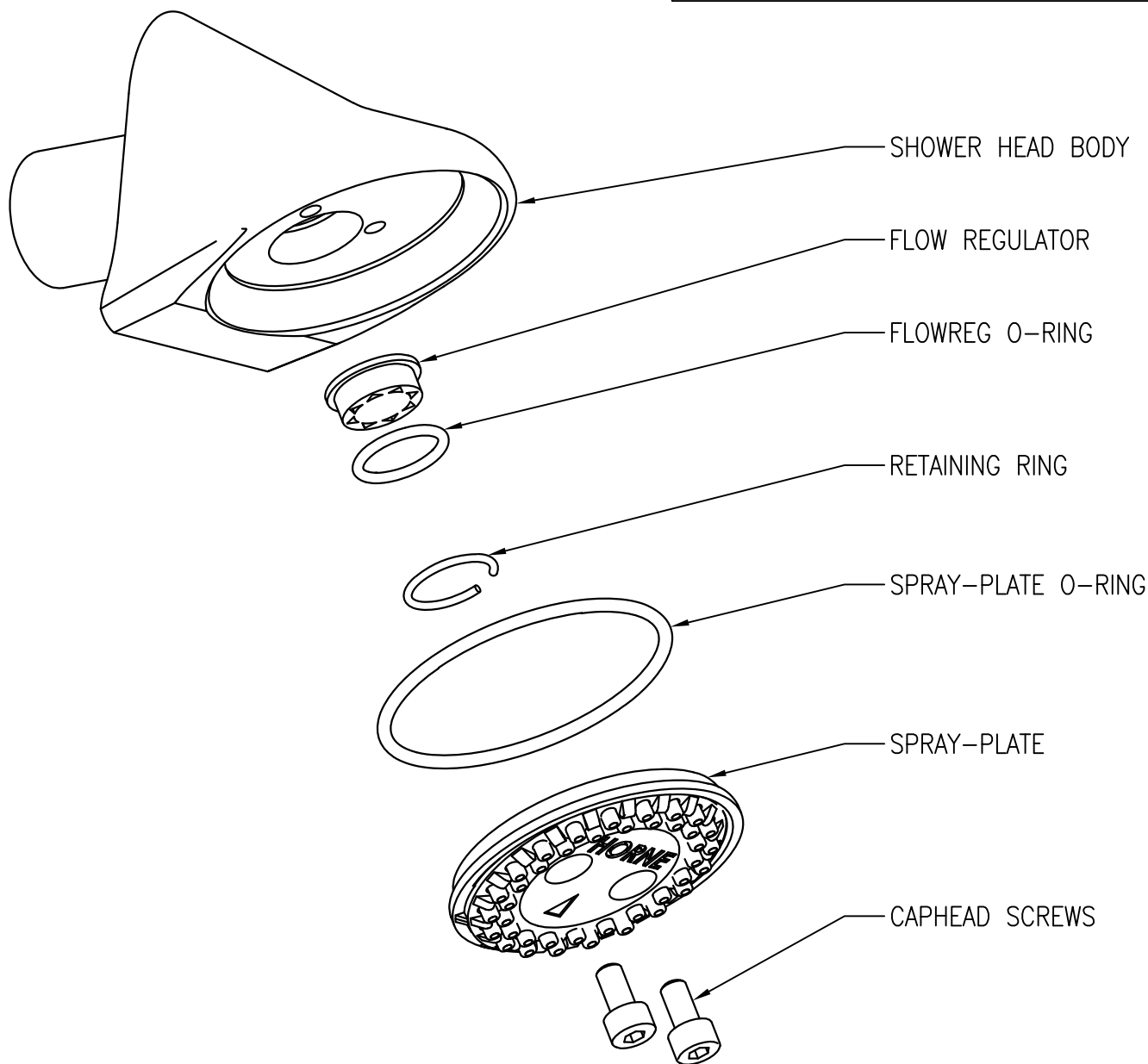

COPYRIGHT 2012, HORNE ENGINEERING LTD. ALL REPRODUCTION PROHIBITED UNLESS AUTHORISED IN WRITING

		MATERIAL : MATERIAL SPECIFICATION		HORNE ENGINEERING LTD. JOHNSTONE RENFREWSHIRE	
PART : REMOVAL / REPLACEMENT OF FLOW REGULATOR (VANDAL RESISTANT HEAD)	PRODUCT : HORNE SHOWER PANELS	SCALE	DO NOT SCALE	DR'G. No. 10393	
		DRAWN	MJ (18/11/2013)		
		CHECKED			
		ISSUE	2		

TO REMOVE FLOW-REGULATOR

1. UNSCREW SPRAY-HEAD FROM ANGLED TUBE
2. REMOVE FLOW REGULATOR AND WASHER
3. REPLACE WASHER
4. REFIT SPRAY-HEAD

TO FIT FLOW-REGULATOR

1. UNSCREW SPRAY-HEAD
2. REMOVE THICK WASHER FROM ASSEMBLY AND FIT FLOW-REGULATOR INSIDE IT (NOTE FLOW DIRECTION)
3. FIT FLOW-REGULATOR AND THICK WASHER TO SPOUT
4. SCREW THE SPRAY-HEAD TO THE SPOUT.

** THE EXACT NUMBER AND THICKNESS OF WASHERS WILL DEPEND ON WHICH SWIVEL-HEAD IS FITTED.

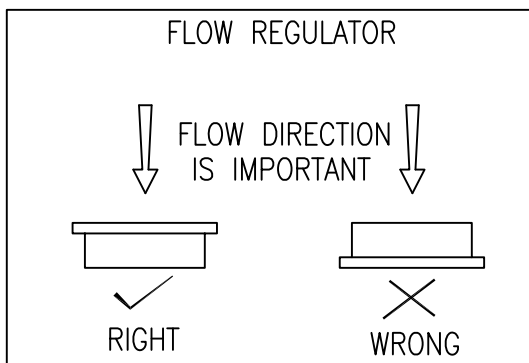
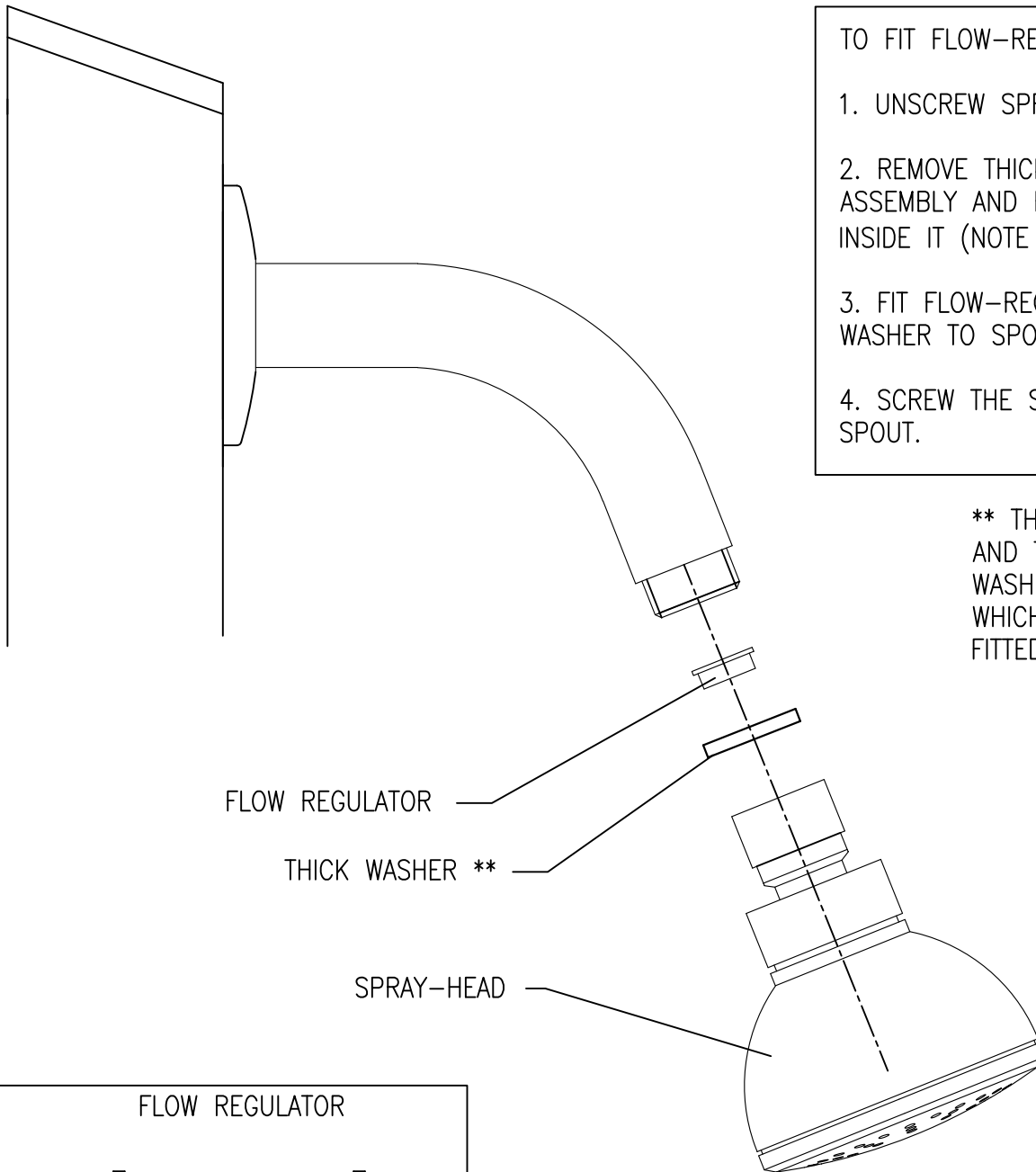

COPYRIGHT 2016, HORNE ENGINEERING LTD. ALL REPRODUCTION PROHIBITED UNLESS AUTHORISED IN WRITING

MATERIAL : N/A

HORNE ENGINEERING LTD.
JOHNSTONE
RENFREWSHIRE

PART :
REMOVAL/REPLACEMENT OF
FLOW REGULATOR

PRODUCT :
TSV1-106A/AB

SCALE	DO NOT SCALE
DRAWN	MJ (1/12/2020)
CHECKED	
ISSUE	5

DR'G. No. 9301B

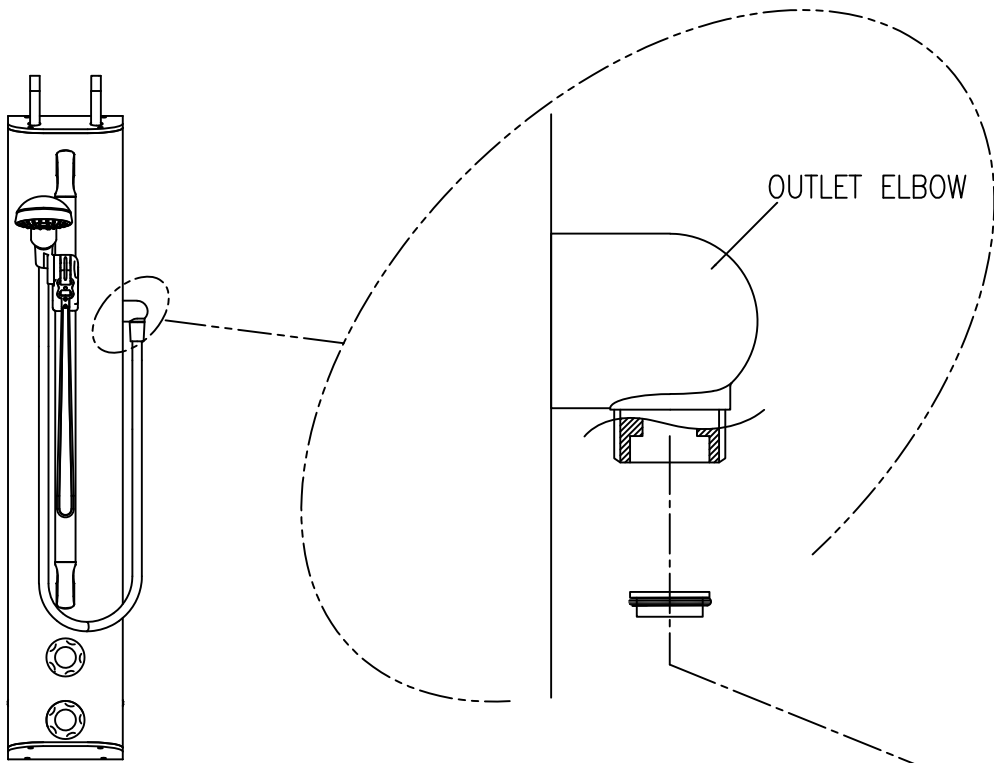

TO REMOVE/REPLACE THE FLOW REGULATOR

1. UNSCREW SHOWER HOSE FROM FIXED END
2. REMOVE, OR REPLACE REGULATOR (WITH O-RING ATTACHED, INTO THE OUTLET ELBOW, FLANGED SIDE FIRST IF REPLACING)
3. ENSURE THAT THE O-RING IS SEATED EVENLY IF REPLACING REGULATOR
4. RE-ATTACH SHOWER HOSE

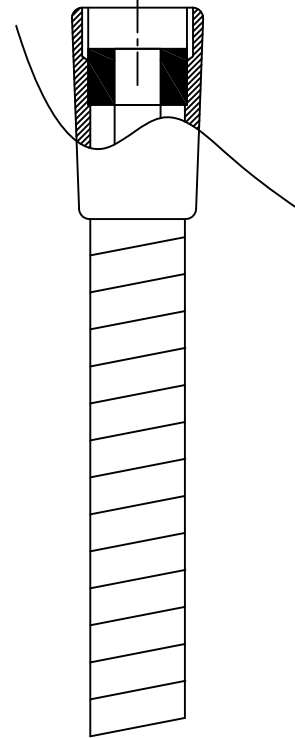

NOTE:
IF REPLACING,
FLOW DIRECTION
IS IMPORTANT



RIGHT



WRONG

COPYRIGHT 2003, HORNE ENGINEERING LTD. ALL REPRODUCTION PROHIBITED UNLESS AUTHORISED IN WRITING

MATERIAL : N/A

HORNE ENGINEERING LTD.
JOHNSTONE
RENFREWSHIRE

PART :
FLOW REGULATOR
REMOVAL/REPLACEMENT
INSTRUCTIONS

PRODUCT :
HORNE SHOWERS
ALL HANDSET MODELS

SCALE	DO NOT SCALE
DRAWN	GDP 7/12/05
CHECKED	
ISSUE	3

DR'G. No. 9302B

INSTRUCTIONS SPECIFIC TO SHOWER UNITS WITH RISER RAIL

TO ADJUST STIFFNESS OF ROTATING HANDSET HOLDER...



PRIZE DECAL COVER OFF HERE

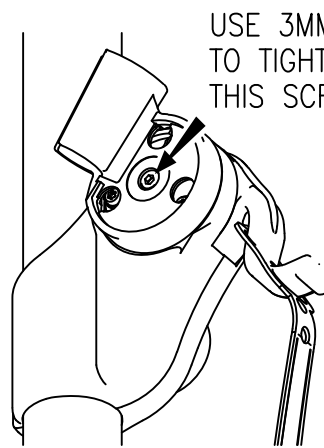

USE 3MM HEX KEY TO TIGHTEN OR LOOSEN THIS SCREW.

TO FIT THE DESCENDER (FOR ACCESSIBILITY)

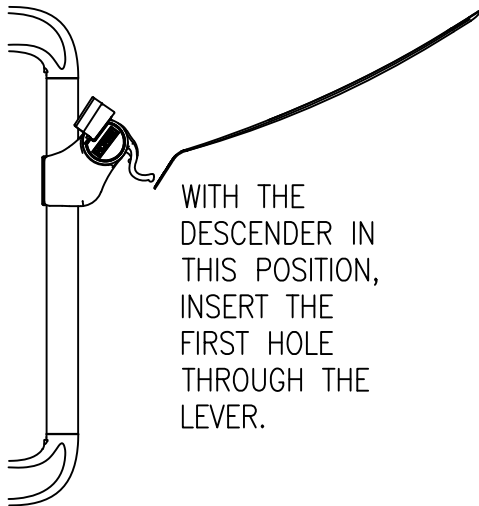

WITH THE DESCENDER IN THIS POSITION, INSERT THE FIRST HOLE THROUGH THE LEVER.

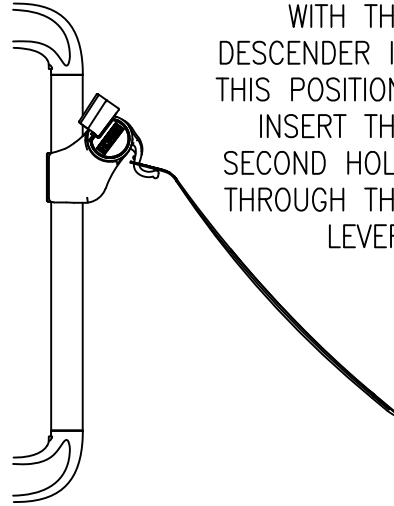

WITH THE DESCENDER IN THIS POSITION, INSERT THE SECOND HOLE THROUGH THE LEVER.

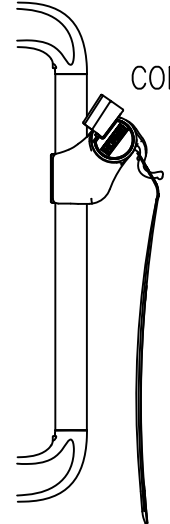

COMPLETE

TO REMOVE HANDSET HOLDER FROM THE RAIL, FIRST REMOVE DECAL COVER (SEE ABOVE), THEN USE TORX T15 DRIVER TO REMOVE THE 3 SCREWS AND THE ROTATING STIRRUP. REMOVE SCREW-COVER* AND SCREW FROM REVERSE OF HANDSET HOLDER, THEN INSERT A 50MM LONG X 3MM DIAMETER ROD (SCREWDRIVER) INTO THE HOLE AS SHOWN. HANDSET HOLDER WILL THEN SPLIT APART AND CAN BE REMOVED FROM THE RAIL.

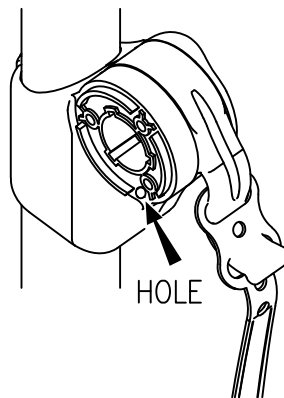

MAXIMUM LOADINGS FOR THE SHOWER RAIL (WHEN USED AS A GRAB-RAIL):-

LENGTH BETWEEN MOUNTING CENTRES	MAX. LOAD
0.8 M	120Kg
0.675 M	150Kg
0.39M	200Kg
0.29M	200Kg

* DRILL A SMALL HOLE THOUGH SCREW-COVER TO REMOVE IT.

HORNE ENGINEERING LTD.
JOHNSTONE
RENFREWSHIRE

DR'G. No. 11399

FAULT FINDING CHART

SYMPTOM	POSSIBLE CAUSE	ACTION	REFER TO SECTION
Mixed water temperature too high	Temperature setting too high. Temperature has been set when the hot water temperature is too low	Re-adjust temperature setting	2.3
	Hot water has migrated into cold water supply	Inspect Check Valve at cold inlet If the check valve leaks replace the strainer body and check valve sub-assembly	3.8 Drg.8314
	Thermostat Element has failed. This can be checked by carrying out a hot or cold-water failure test.	Replace element (11)	3.4
Mixed water temperature too low	Temperature Setting too low	Re-adjust temperature setting	2.3
	Hot water supply temperature has fallen	Check hot water supply system	0.4
	Cold water has migrated into hot supply	Inspect Check Valve at hot inlet If the check valve leaks replace the strainer body and check valve sub-assembly.	3.8 Drg 8314
	Cold valve face requires cleaning	Remove valve Cover (14) and service valve face	3.6.2
Mixed water flow rate too low.	Partly blocked strainers	Clean strainers (4)	3.3
	Unusually high pressure-drop in supply pipework	Check all valves are full open. Check Pressurisation unit Check mains supply	
	Extra Demand added to system	Check pipe sizing	
Mixed water temp does not respond to adjusting screw	Slide-Valve (10) is seized	Valve requires de-scaling	3.6
Mixed water temp changes and is not steady	Slide-Valve (10) is seized	Valve requires De-Scaling	3.6
	Thermostat element has failed (This can be checked by carrying out a hot or cold-water failure test)	Replace element (11)	3.4
Valve continues to pass cold-water when hot supply is isolated	Cold valve face requires cleaning	Remove valve cover (14) and service cold valve face	3.6.2
	Fouling at hot valve seat	Clean hot valve face	3.6.2
Valve continues to pass hot water when cold supply is isolated	Slide-Valve seal is damaged	Replace Slide-Valve Seal (9)	3.2.1
	Element has failed	Replace Element (11)	3.4

COMMISSIONING, MAINTENANCE & IN-SERVICE TESTING RECORD

Establishment:					
Type of Valve: Horne TSV1-3 Shower Valve			Date Installed:		Installed by:
Location of Valve:					
Commissioning Details [Fill in ALL information during commissioning]					
Hot Water Supply :	HW Temp	°C	HW Pressure	Bar	Instrumentation: Temp: Pressure:
Cold Water Supply:	CW Temp	°C	CW Pressure	Bar	
Mixed Temp at max draw-off:	Mixed Temp: °C		Flowrate at max draw-off: l/min		
Mixed Temp at low draw-off:	Mixed Temp: °C		Flowrate at low draw-off: l/min		
Instrumentation Used:	Temp:		Press:		Flow:
Cold Water Isolation Test	Max Mixed Water Temp during CW Isolation test: °C Mixed Water Temp on restoration of CW Supply: °C Note: MWT should return within 2 degrees of set temp, and be no greater than 43°C after this test.				
Comments:					

In-Service Testing Record		Establishment:		Location of Valve:	
Date:		Type of Valve : <i>TSV1-3 Shower Valve</i>			
Hot Water Supply :	HW Temp	°C	HW Pressure	Bar	Instrument used (temp): Instrument used (pressure):
Cold Water Supply:	CW Temp	°C	CW Pressure	Bar	
Mixed Temp at max draw-off:	Mixed Temp:	°C	Flowrate at max draw-off:	l/min	
Mixed Temp at low draw-off:	Mixed Temp:	°C	Flowrate at low draw-off:	l/min	
Instrumentation Used:	Temp:		Press:	Flow:	
Cold Water Isolation Test	Max Mixed Water Temp during CW Isolation test: °C				Mixed Water Temp on restoration of CW Supply: °C
MWT should return within 2 degrees of set temp, and be no greater than 43°C after this test.					
Comments:				Recommended Date of Next In-Service Test:	

In-Service Testing Record		Establishment:		Location of Valve:	
Date:		Type of Valve : <i>TSV1-3 Shower Valve</i>			
Hot Water Supply :	HW Temp	°C	HW Pressure	Bar	Instrument used (temp): Instrument used (pressure):
Cold Water Supply:	CW Temp	°C	CW Pressure	Bar	
Mixed Temp at max draw-off:	Mixed Temp:	°C	Flowrate at max draw-off:	l/min	
Mixed Temp at low draw-off:	Mixed Temp:	°C	Flowrate at low draw-off:	l/min	
Instrumentation Used:	Temp:		Press:	Flow:	
Cold Water Isolation Test	Max Mixed Water Temp during CW Isolation test: °C				Mixed Water Temp on restoration of CW Supply: °C
MWT should return within 2 degrees of set temp, and be no greater than 43°C after this test.					
Comments:				Recommended Date of Next In-Service Test:	