

## APPLICATIONS

Thermostatic mixing of hot and cold water to provide safe and comfortable water, typically to a group of taps or showers at a controlled temperature over a wide range of flow rates. DN25 TMV for connection to 28mm copper pipe.

## KEY FEATURES

- Every valve performance tested in production
- Accurate and reliable temperature control
- Automatic shut down if hot or cold water supply fails
- Full bore fine mesh strainers help protect internal valve mechanism and all downstream fittings
- Easy installation, commissioning and maintenance
- Available with hygiene white plastic anti-tamper cover
- UK Water Reg 4 approved (non-metallic materials in contact with potable water)



HORNE 25 with integral check valves and strainers



HORNE 25 with integral check valves, strainers and wall mounting bracket.

## SPECIFICATION REFERENCES

The Horne 25 is available in either bronze (B) or chrome (C) finish in the following configurations:

HORNE 25 TMV	PRODUCT REF
WITH integral check valves and strainers.....	<b>H25-11B</b> <b>H25-11C</b>
PLUS wall mounting kit.....	<b>H25-12B</b> <b>H25-12C</b>
PLUS white plastic cover.....	<b>H25-13B</b> <b>H25-13C</b>



HORNE 25 with integral check valves, strainers, wall mounting bracket and white plastic cover.

## DIMENSIONS

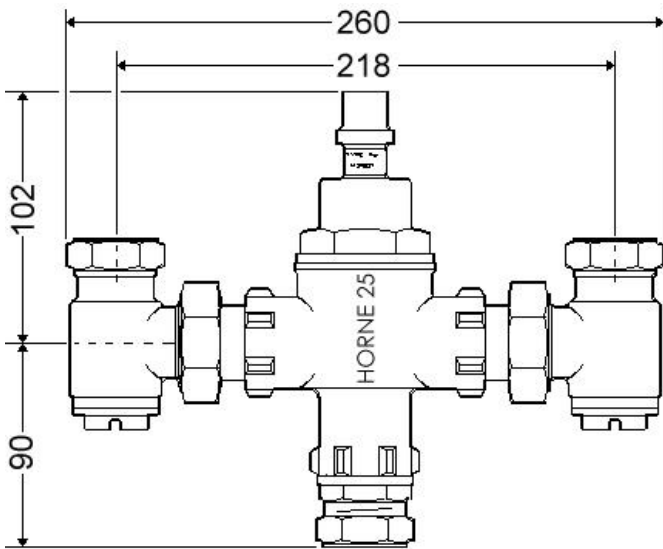

**H25 -11B / C**

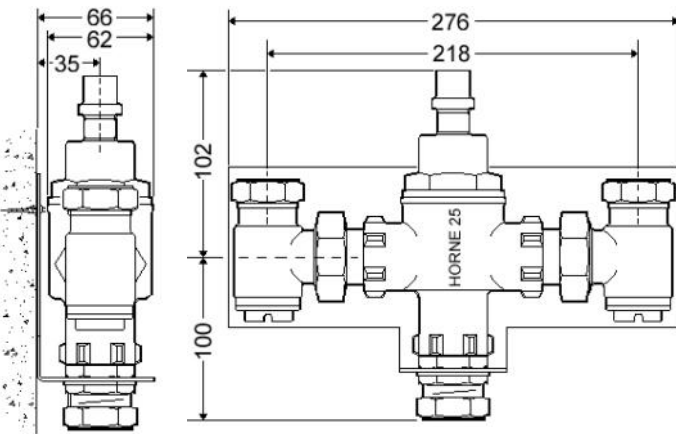

**PROFILE**

**H25-12B / C**

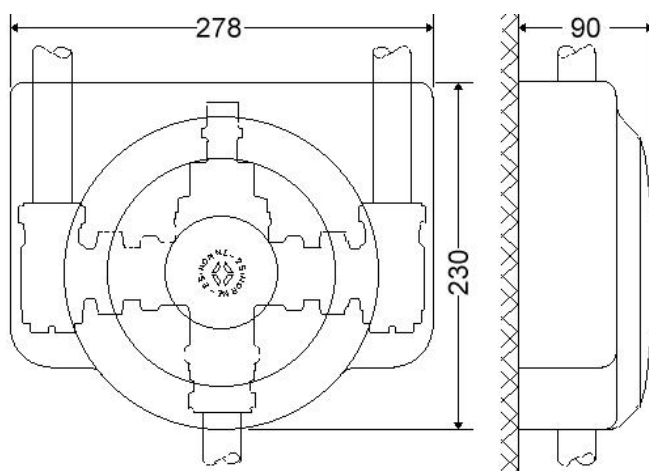

**H25-13B / C**

## TYPICAL INSTALLATION

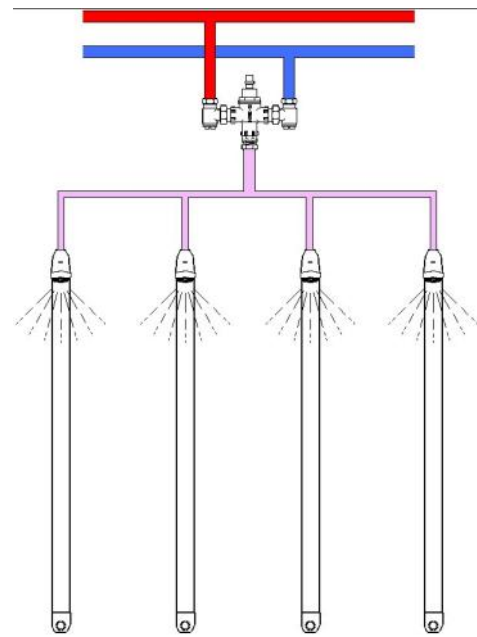

A group of Horne Dušo shower columns supplied with mixed warm water from a Horne group TMV.

## SIZING CHART

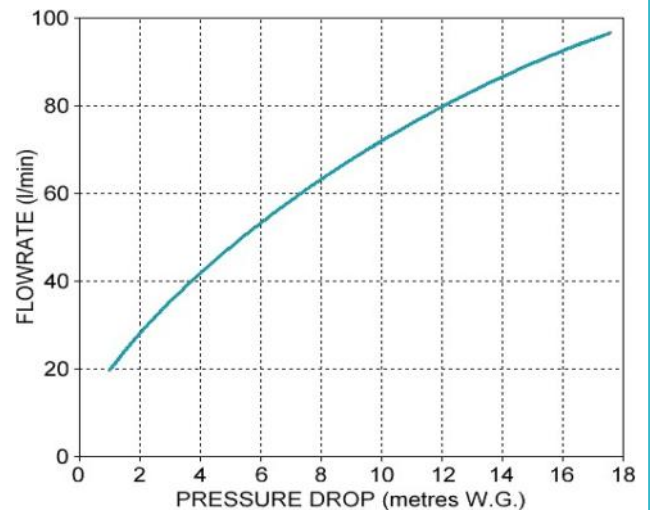

## OPERATING PARAMETERS

Temp. setting at factory	41°C
Range of temp. adjustment	25 - 50°C
Range of hot water supply temp.	55 - 85°C
Minimum differential between hot water temp. and mixed water temp.	12°C
Maximum static pressure	10 bar
Range of maintained water supply pressures	0.2 - 5 bar

Note: supply pressures should be approximately equal.