

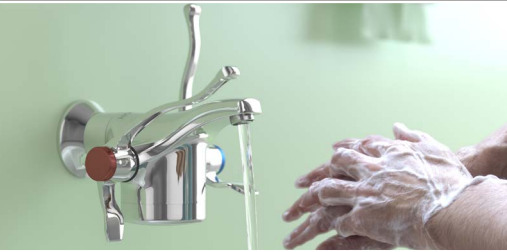

NBS Source
PARTNER

Pr_40_20_87_87 Thermostatic mixer taps
Pr_40_20_87_50 Lever-action bib taps
Pr_40_20_87_94 Wall-mounted lever-action bib taps
Pr_40_20_87_93 Wall-mounted bib taps
N13/362 Bib taps
N13/24 Bib taps

thermostatic tap specification manual



 **OPTITHERM®**
The optimum in safety and control

HORNE

contents

introduction to HORNE	2
the design brief	3
safe hot water & surface temperatures	4
hand hygiene & infection prevention	5
installation & commissioning	6
performance testing & maintenance	7
water system management	8
options	9
tap dimensions/CAD drawings	10
accessories	11

 **OPTITHERM®**

 **NBS**



A fully illustrated and narrated product tour is available to view at <http://b.link/SafeHands>
Horne Engineering Ltd reserves the right to alter any product, design or specification without notice.

introduction

HORNE

2

OPTITHERM®



HORNE Engineering have been designing, developing and manufacturing thermostatic valves since 1909.

Over the years we have continually improved and refined thermostatic temperature control technology and its application. Our product portfolio includes a broad range of specialised thermostatic mixing valves and shower valves developed to address the needs of a variety of niche applications. Now our product range has been extended further with the production of our first thermostatic tap – the award-winning* OPTITHERM®.



*Best Interiors Product, Building Better Healthcare Awards 2008

The OPTITHERM® has an integral Thermostatic Mixing Valve that is certified as a UK Water Regulation 4 and Type 3 Approved mixing valve (see www.horne.co.uk for further information and current approval certificates) in compliance with NHS Health Technical Memorandum 04-01 (D 08 supplement): Model engineering specifications D08 Thermostatic mixing valves (healthcare premises) and BS 7942.



DESIGN CONCEPT AND EVOLUTION

The OPTITHERM® is a highly specialised thermostatic tap developed principally for clinical and surgical hand decontamination in healthcare applications. We set out to achieve a design that meets the needs of a variety of users looking for the following key features:

- ease of use
- consistent delivery of safe and comfortable hot water
- Legionella control - every operation, mixed or cold, turns over cold water
- easy access for testing and maintenance
- optimised user interface - to enhance hygiene compliance
- easy cleaning for improved hygiene
- robust construction
- compliance with a range of healthcare related regulations and published guidance
- efficient use of energy and water
- minimisation of coldwater dead legs

A recent update to the Optitherm's design has reduced brass and chromium plating volumes, whilst also further minimising the mixed water deadleg.

safe hot water & surface temperatures

HORNE

4

OPTITHERM®

The consistent delivery of 'safe' hot water is an essential component in the provision of good healthcare.

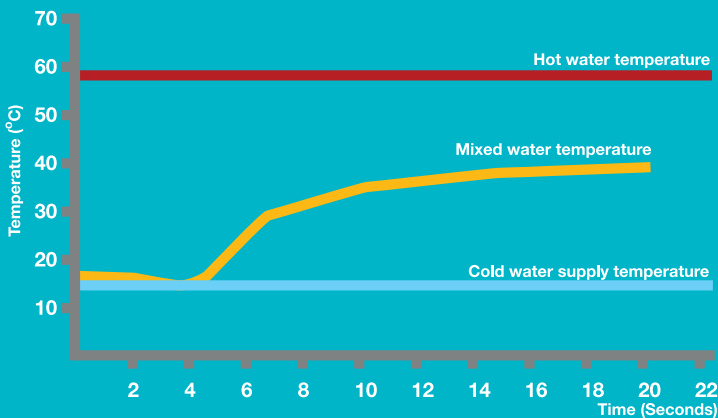

Safe temperature, safe hands

SAFE HOT WATER

It is common for thermostatic mixing valves to produce a transient temperature 'spike' when starting from ambient as the proportioning device in the mixing valve moves to the desired position. This can become a disincentive to hand hygiene compliance. As such, the Optitherm's highly responsive thermostatic mechanism displays exceptional performance; removing any ambient start transient.

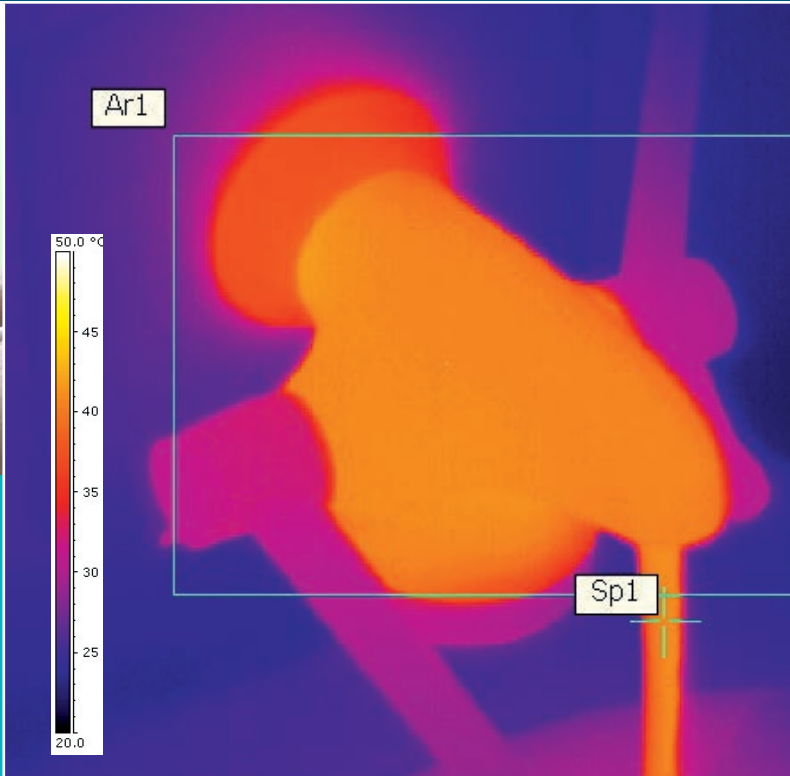

ANALYSIS

Ar1 Min 21.8°C Max 41.8°C Average 33.7°C

Sp1 41.0°C

OPTITHERM® thermal image

SAFE SURFACE

The OPTITHERM® should be supplied with hot water at a temperature that will typically be in the range of 55°C – 65°C, which is then mixed with cold water inside the tap to produce mixed water at safe, consistent and comfortable level. It is essential that the temperature of the outer surface of a tap does not become dangerously high during and immediately after periods of operation. The thermal image above demonstrates how the temperature of the outer surface of the OPTITHERM® remains at a safe level during operation, and never exceeds 43°C as per HSE Information Sheet: Managing the risks from hot water and surfaces in health and social care.

hand hygiene and infection prevention

Fixtures and fittings used by healthcare staff and patients should be designed, wherever possible, to contribute to enhanced infection control, and perform in a manner that is conducive to maintaining excellent compliance with hand hygiene.



A



B



OPTITHERM®

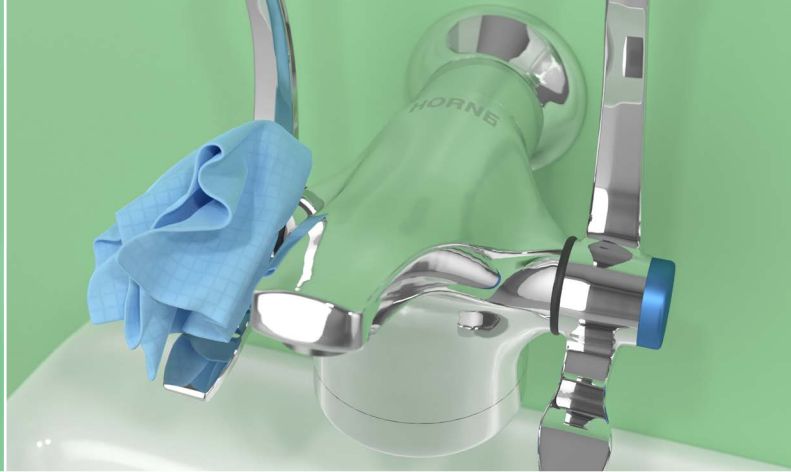

Correct operation prevents re-contamination

Smooth and accessible surface for complete cleaning

USER OPERATION

Reliable, repeatable actuation is provided in the mechanical lever on-off control, which also affords 'hands free' operation.

Our unique double lever option allows for the lever to be pushed on using a single thumb (A) but, crucially, after hand washing, the elbow or upper forearm is used, again in a forward movement (B), to close the flow keeping the hands away from the face and hair. Flow rate is also important for a user-friendly experience; a 6 L/min flow regulator and laminar flow conditioner ensures water is delivered in a controlled manner, without excessive noise or potentially hazardous splashing, that is conducive to good hand washing practice.

On flow closure return the lever to an upright orientation. Note that a robust clutch mechanism protects the lever from heavy handling or willful damage.

EASE OF CLEANING

The OPTITHERM® has been designed to ensure that all areas of its outer surface are fully accessible for easy and effective cleaning. There are also no parts that can be prised off leaving recesses, which can harbour dirt and pathogens.

We recommend a single-use cleaning cloth be used to clean the Optitherm tap and a separate, single-use cloth for cleaning the basin.

installation & commissioning

HORNE

6

OPTITHERM®



A complete and effective commissioning procedure will help to ensure the correct operation of the hot and cold water systems.



Flush pipework after spigot installation



Install and commission during final fit-out

INSTALLATION

Installation of the OPTITHERM® is particularly easy and can be achieved in two stages. The spigot can be installed at the same time as the water supply pipe work and wall panelling.

A Flushing Boot (part number 5684) fits over the spigot such that, in accordance with Water Supply (water fitting) Regulations, pipe work flushing can be carried out as soon as water is available on site. This spigot mounted flushing boot also better facilitates the required thermal and chemical disinfection of the hot and cold water system *before* the tap body is installed on the spigot.

COMMISSIONING

The OPTITHERM® tap assembly may be fitted to the spigot and commissioned during the final build phase. This greatly reduces the risk of damage or contamination to the tap, (plastering and painting etc. around the wash hand basin). The OPTITHERM® can only be properly commissioned, and its temperature set, once hot water is available and this is very often only in the latter stages of the build programme.

We recommend the current commissioning instructions be followed including thermal disinfection of the tap's internal surfaces using the Horne In-line Thermal Disinfection Unit (ILTDU) - further information on page 8.

performance testing & maintenance

To achieve consistent and accurate performance over a maximised lifespan, the design must facilitate easy access for routine testing and maintenance.

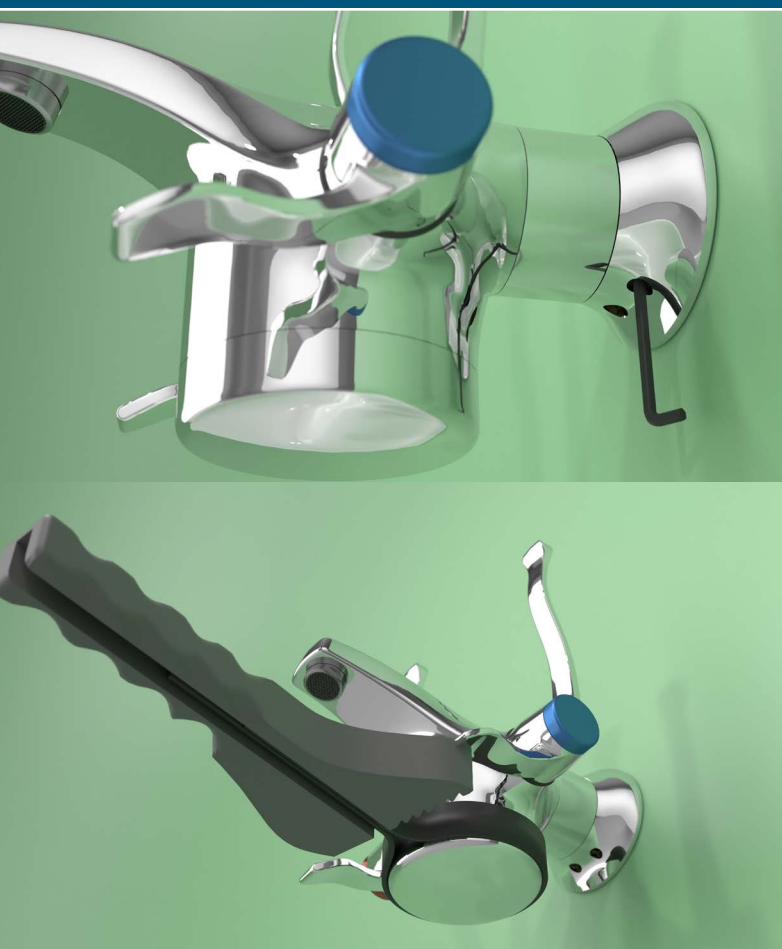

Isolating servicing valves are located under the tap spigot



Internal components are all easily accessed for cleaning and maintenance

ACCESSIBILITY

The thermostatic control is integral to the OPTITHERM® and, with the correct tools and equipment (see Accessories on page 11), is easily accessible by facilities management personnel.

Isolating servicing valves, integral to the spigot, are accessible without the need to remove the tap or any wall panelling. The servicing valves facilitate simple performance testing (cold water supply closure), as well as isolation for high velocity flushing, in-situ maintenance or tap substitution.

STRAINER

Hot and cold strainer and check valve cartridges are accessible for routine cleaning – the strainer basket is removable to aid rinsing and disinfection.

THERMOSTATIC CARTRIDGE

The thermostatic cartridge is easily removed when due for cleaning or replacement (every 3 years recommend).

water system management – thermal regime

HORNE



The product should be so designed to facilitate best practice water system management with respect to microbiological contamination.

8

OPTITHERM®

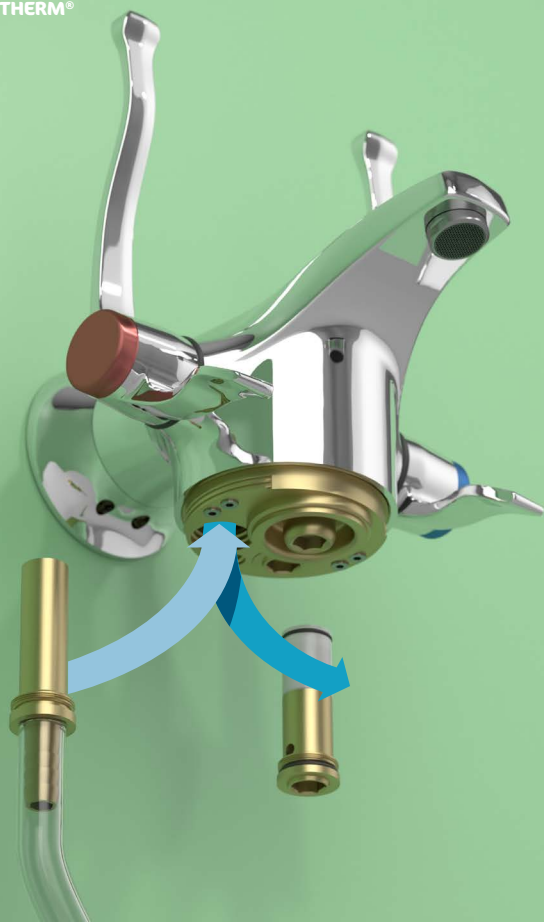

Simple and effective flushing and sampling procedure

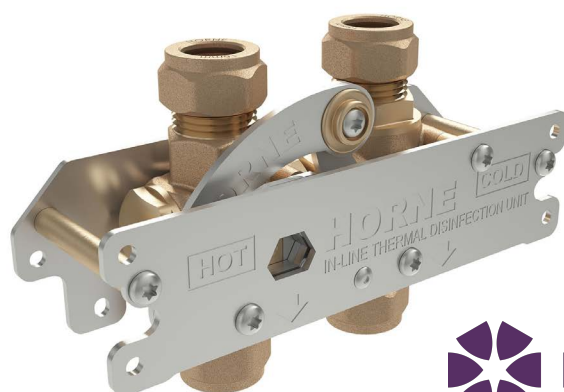

Thermal disinfection in-situ using the ILTDU

FLUSHING, TESTING & SAMPLING

The Optitherm Flushing Kit (part no. 5492) facilitates regular *elevated velocity* flushing of the supply pipework. Effective immediately upstream of the mixing valve, higher flow velocities can be achieved; upsetting the flow equilibrium and mechanically shearing excess biofilm from the internal pipe surfaces, which is then suspended in the hastened flow and removed to drain - thus improving quality of water entering the tap and mixing chamber.

The Flushing Kit also allows for water supply temperature testing and sampling for micro-biological analysis.

THERMAL DISINFECTION

Thermal disinfection is recommended, as part of the commissioning process and regularly, as part of a planned preventative maintenance regime, to reset retrograde pathogens (e.g. *Pseudomonas Aeruginosa*, Nontuberculous Mycobacteria) to zero.

Installed across the hot and cold water supplies, the Horne ILTDU - In-line Thermal Disinfection Unit, allows for quick and simple thermal disinfection with system temperature hot water - sanitising all downstream components and internal surfaces to the point of water delivery.

A narrated animation describes retrograde contamination, the thermal regime, ILTDU operation and safety considerations.

<http://b.link/Pathogen-Control>

To minimise retrograde contamination of the water system, water must not be allowed to fall directly into the drain or trap.

Dual levers, no extension piece - suitable for pairing with a 400mm clinical wash hand basin.

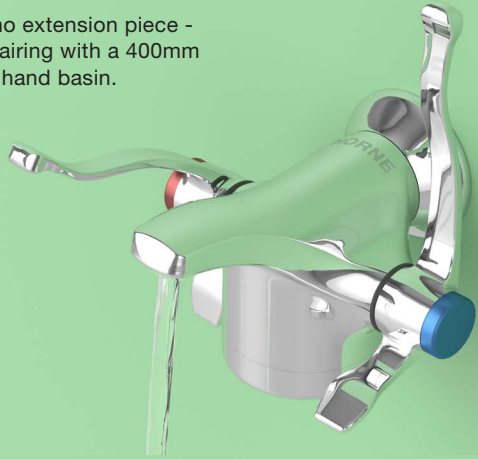

Dual levers, 30mm extension piece - suitable for pairing with a 500mm clinical wash hand basin.

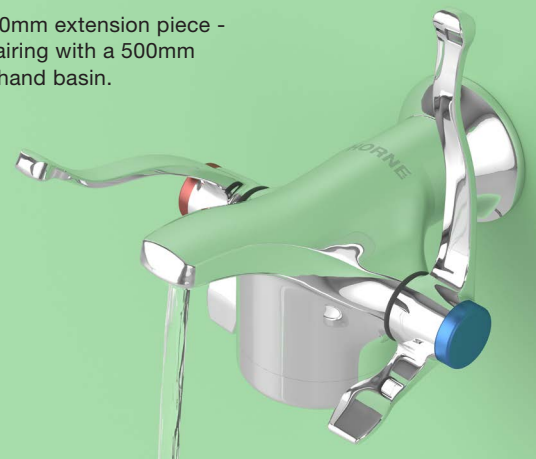

Dual levers, 60mm extension piece - suitable for pairing with surgical scrub or sluice sink.

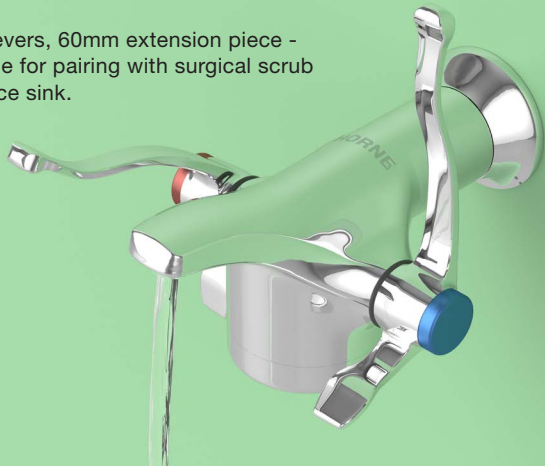

OPTIONS

The OPTITHERM® is supplied with our patented dual levers for effective hands-free operation and improved infection control. The point of discharge, which affects where the column of water falls into the basin, can be adjusted with

the inclusion of a 30mm or a 60mm spacer / extension piece. The standard outlet fitting, a combined flow regulator and conditioner, serves a critical function in further reducing the risk of retrograde contamination.



The strip of images above are taken from the fully narrated animation which can be found at <http://b.link/SafeHands>

tap dimensions/CAD drawings

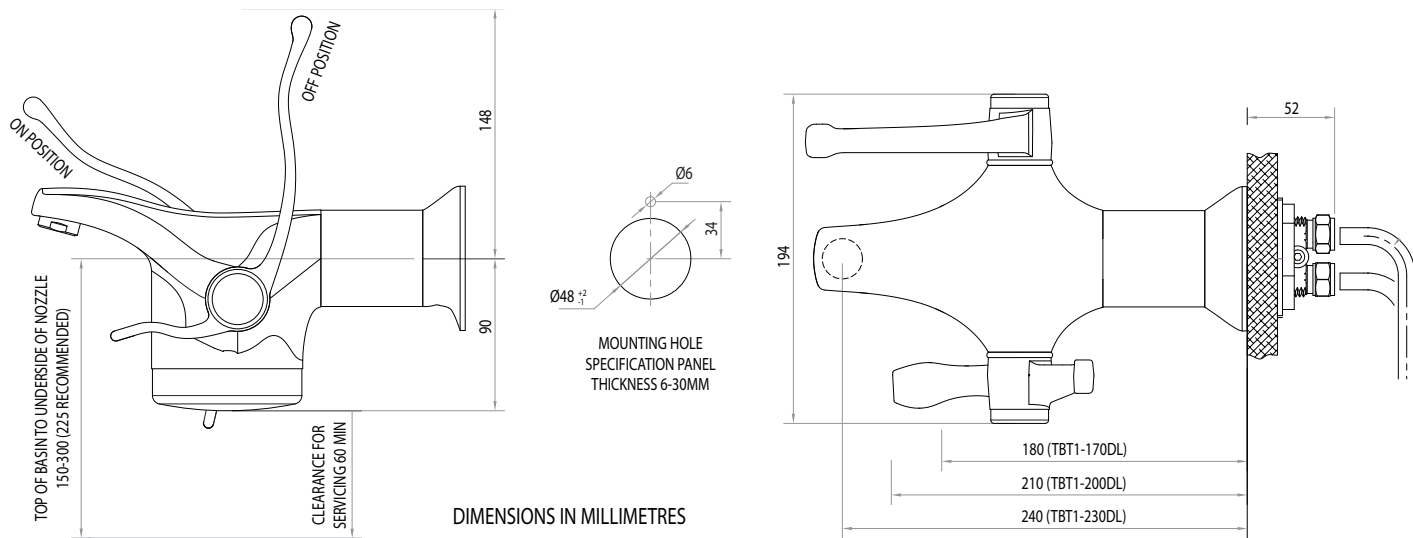

Product References

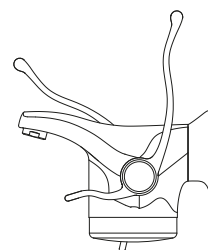
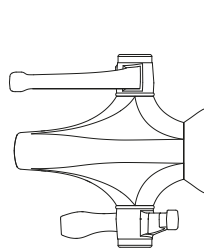
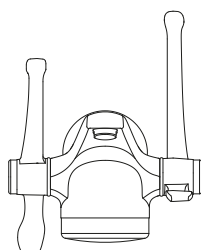
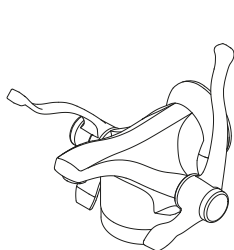

TBT-170DL No extension piece, dual levers

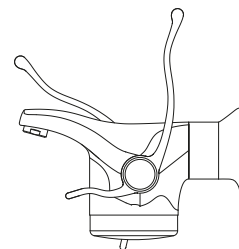
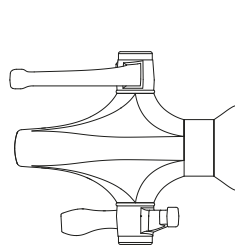
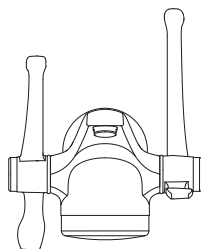
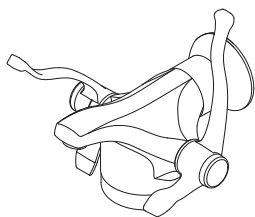

TBT-200DL 30mm extension piece, dual levers

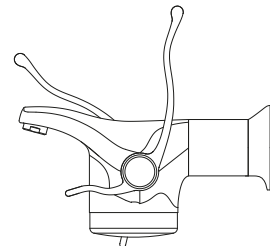
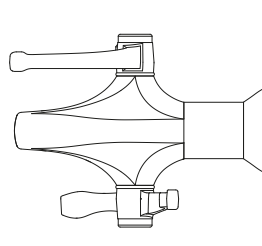
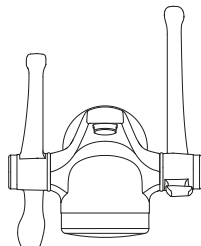
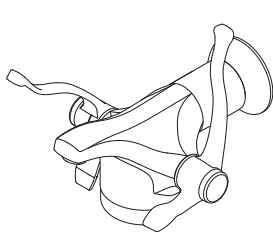

TBT-230DL 60mm extension piece, dual levers

Further Reading

Health Technical Memorandum 04-01: 'The Control of Legionella, Hygiene, "Safe" Hot Water, Cold Water and Drinking Water Systems: Part A (Design, Installation & Testing) and Part B (Operational Management)', 2016.

HTM 04-01 Supplement: Performance Specification D08 thermostatic mixing valves (healthcare premises), 2017

University of West London, Epic 3 Guidelines: National Evidence-Based Guidelines for Preventing Healthcare-Associated Infections in NHS Hospitals in England.

Health and Safety executive: Managing the risks from hot water and surfaces in health and social care.

HBN 00-09: Infection control in the built environment. HBN 00-10 Part C: Sanitary assemblies. Department of Health, 2013.

Hand Decontamination Guidelines. Infection Control Nurses Association

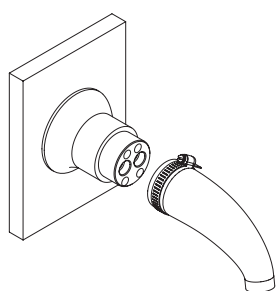

Spigot Flushing Boot

PART No 5684

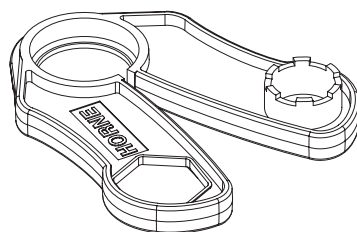

Multitool

PART No 5459

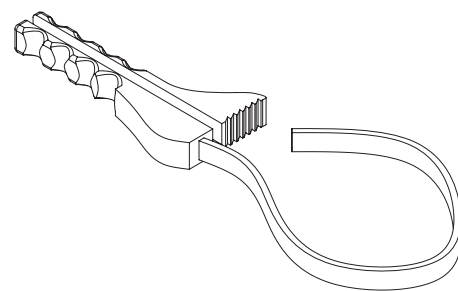

Strap Wrench

PART No 5457

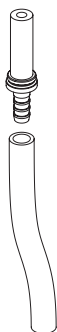

Flushing/Sampling Kit

PART No 5492

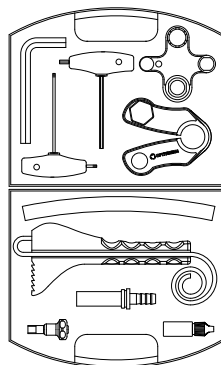

Toolkit

PART No 5491

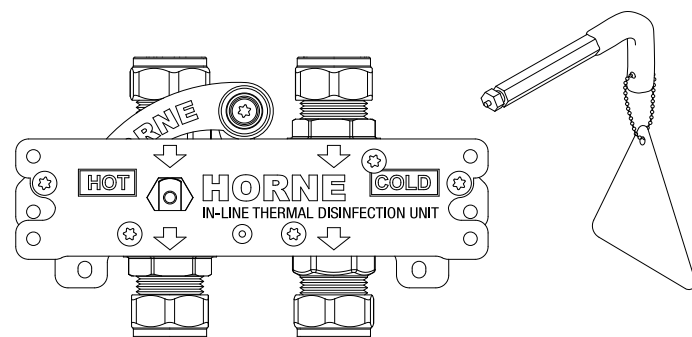

Horne In-Line Thermal Disinfection Unit

PART No ILTDU and 6236 KEY

OPTITHERM® TOOL KIT

A special toolkit (part no. 5491) is available to aid maintenance of the OPTITHERM® tap and includes the following items (some pictured above):

- Universal outlet fitting key
- Multi-tool
- 2 No. hex keys
- 1 no. Torx T20 key
- Strap wrench
- Thermostatic cartridge removal tool
- Flushing/Sampling kit
- Oil bottle

IN-LINE THERMAL DISINFECTION UNIT, ILTDU

May be installed upstream of the Optitherm (or any tap, thermostatic mixing valve or shower valve) and facilitates periodic in-situ thermal disinfection, using the readily available system temperature (60°C) hot water supply. With the ILTDU installed, thermal disinfection is easily incorporated into a PPM, planned preventative maintenance, regime.

A narrated animation describes retrograde contamination, the thermal regime, ILTDU operation and safety considerations.

<https://b.link/Pathogen-Control>

HORNE

HORNE ENGINEERING Ltd
PO Box 7, Rankine Street
Johnstone, United Kingdom PA5 8BD
tel +44 (0)1505 321455
fax +44 (0)1505 336287
email sales@horne.co.uk
web www.horne.co.uk

HORNE and **OPTITHERM**[®] are trade marks or registered trade marks of Horne Engineering Limited

Design rights and Copyright Horne Engineering Limited 2022

Patented:

Dual Lever Action EP1963724;

Integrated TMV with dedicated cold control EP1963723;

Integrated TMV serviceability features EP1965109.

Design Registrations:

Mixing Taps (part of -) EU000451489-0001 to 0003.

All Rights Reserved.